



Friso van Dijk

Selected works

2019-2022



Friso van Dijk

Nationality Netherlands
 Date of Birth 24 June 1996
 Address Havenstraat 146
 Rotterdam
Mail friso@frisovdijk.com
Number +316 39 121 619
 Website frisovdijk.com
 Instagram /vandijkfriso
 LinkedIn /in/friso-van-dijk-890140172/

Languages

Dutch Native
 English Fluent
 German Basic
 French Basic

Skills

Physical
 Modelmaking
 (Stone) Carving
 Woodworking
 Photography
 Sewing

Digital
 3D modelling
 Rhino, Maya, Archicad, Revit,
 Autocad, Fusion360
 3D Printing
 Simplify3D, Cura, Meshmixer
 Lasercutting
 3D Rendering
 Vray, Maya, Lumion, Enscape
 Parametric Design
 Grasshopper, Ladybug,
 tOpos, Galapagos
 Adobe Suite
 Photoshop, Illustrator,
 Indesign, Premiere Elements,
 Lightroom
 Website Building
 Wordpress, HTML, CSS

Soft Skills

Conceptual Thinker
 Solution Oriented
 Fast Learner
 Collaboration
 Versatility

Experience

Rotterdam
 2020
 6 months
Architecture intern, Powerhouse Company
 Worked in two different teams, the first two months mostly working on domestic projects in the further stages of the process. The last four months were spent in the pitch or concept team, where I took part as a designer in the concept phase for competition entries.

Projects
 Amsterdam
 Tasks: IBM Headquarters (mixed use - competition winner)
 Office space studies, Interior Floor Plans

Amsterdam
 Tasks: Confidential (residential)
 Facade studies, floor plans

Chengdu
 Tasks: Confidential (Headquarter office, hotel, sports venue)
 Volume studies, facade studies, parametric design, diagrams, renders, animations

China
 Tasks: Confidential (residential)
 Volume studies, facade studies, parametric design, image production

Copenhagen
 2019-2020
 6 months
Design Assistant, BIG (Bjarke Ingels Group)
 Worked with one team to contribute continuously to the growth of multiple projects. With a focus on creating reusable housing concepts. All projects were mixed-use with a residential aspect.

Projects
 Copenhagen
 Tasks: Kaktus Towers (residential - mixed use)
 Facade studies, Parametric design, Rendering, Sections and plans

Copenhagen
 Tasks: Confidential (residential - sports venue)
 Volume studies, facade studies, 3D models, physical models, diagrams

Lyngby, Horsens & Aarhus
 Tasks: Confidential (residential - mixed use)
 Volume studies, facade studies, 3D models, physical models, diagrams

artist
 2021-present
Photographer
 Photography as a form of artistic expression, photographing on commission and selling prints. Featured in photography exhibitions, galleries and magazines.

freelance
 2017-present
Webdesigner / graphic designer / communications officer
 Designing, Building and maintaining all sorts of websites and their content. Mostly for NGO's and ZZP'ers in the intercultural Communications and Diversity and Inclusion sector. The work revolves around working in the backend to ensure everything works as intended and designing the frontend and keeping it user friendly.

Education

2020-2022
MSc, TU Delft Bouwkunde
 Cum Laude Masters of Architecture

2021-2022
 Borders & Territories Graduation Studio
 Honourable Mention

2021
 MSc 2 Studio - Interactive Architecture

2020
 MSc 1 Studio - The Why Factory

2016-2019
BSc, TU Delft Bouwkunde
 Bachelor of Architecture

2018-2019
 Minor - House of the Future

2015-2016
BSc, TU Delft Industrial Design
 Not my cup of tea

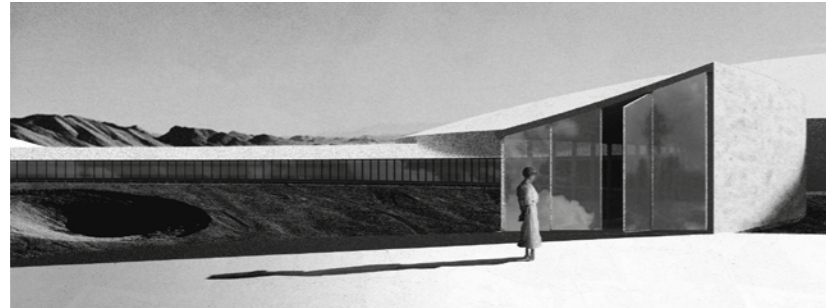
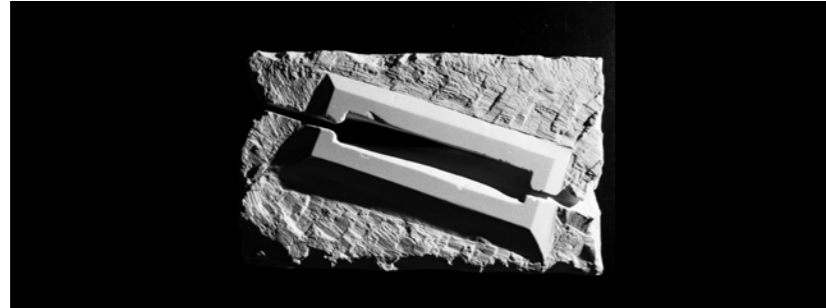

Project Index

Selected Works:

1. In Shadows we Boogie
2. Anomalous Marseille
3. No More Shadows
4. Memories of the Future

Photography:

- A City From Shadow
- Crown of the Industry
- Lost in Mars

Addendum / one page projects:

1. Archipelago
2. The Enclave
3. A Moment Captured
4. David After Goliath

In Shadows we Boogie

Light, shadow and the repression of darkness

TU Delft | Academic | Graduation (Cum Laude) | Honourable mention | 2021-2022

Light, shadow and shade are at the foundation of our cartesian understanding of 3D space. Where light falls on matter the difference in shading allows us to see this space. However, light also breaks this understanding creating the potential for a phenomenological understanding instead. Which is seen with an extradimensionality in certain situations, where space does not make sense. In this moment, where matter falls on light, the very fabric of the world is distorted.

My thesis investigates what happens in between these moments, the infinite movement within the finite moment. The spatial implications of the movement between states are echoed in the material approach, where the relation between figure and ground is investigated and reversed. The polished building and the resulting quarry become the polished quarry and the resulting built form. Creating a monolithic structure, suspended in different states, at once a careful balance between addition and subtraction and between matter and light as principal shaper of space.



fig 1. site location, Île de Ratomeau

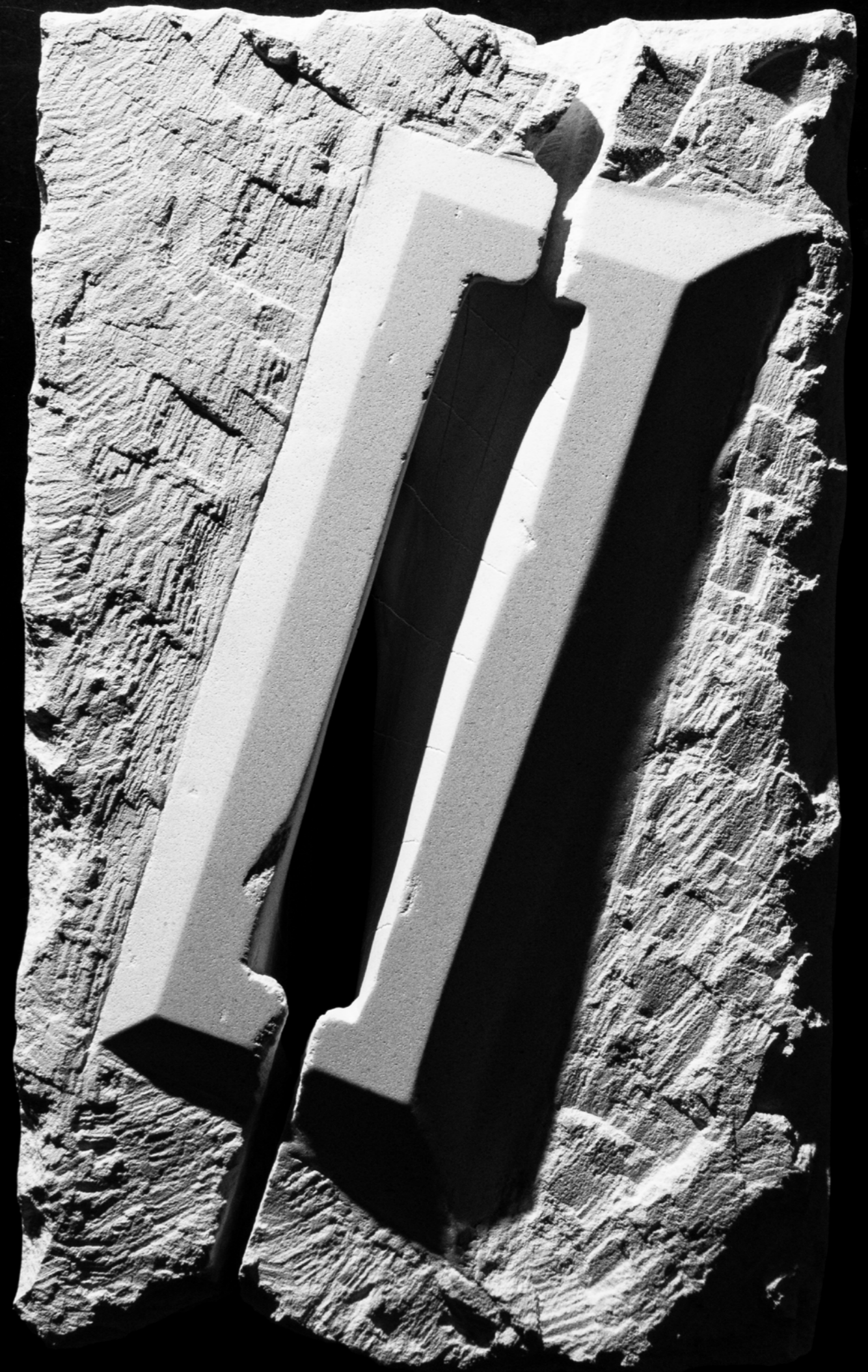

fig 2. Physical model, carved out of limestone from near the site

To better understand this moment of becoming, as it presents itself in space, the relation between shadow and perception must be investigated. Considering the meaning of “drawing with light”, photography presents itself as an appropriate medium for mapping shadow. Photography however has traditionally been essentially representational, which is not the point of this exercise. As Malevich has shown the death of representation in painting in ‘Black square’, the movement beyond representation is not new, nor impossible the painting appearing vaguely like a negative that was developed without being exposed through a camera. This photography without the use of a camera, is what would become non-representational photography, this however strays too far from capturing perception to be of much use in this mapping either.

The approach of non-objective photography lends itself to mapping from within the phenomenon of shadows, as it allows photography to stray from dealing only with the truth. This is especially relevant considering shadows’ ability to disassociate themselves from the cartesian truth. This implied dissociative nature of shadows renders the whole notion of cartesian truth of the city irrelevant, making an analog approach to photography favourable. The temporal displacement between closing the shutter and seeing the final developed image encourages a stronger emphasis on the photograph as perception of the city, rather than the memory of taking it, adding to the dissolution of meaning. On these grounds analog, black-and-white photography was used as a medium for generating images.

80 out of 224 pictures taken were randomly selected and bundled in the book, which functions as a map of marseille through photography alone.

fig 3, 4, 5. Excerpts from my book



fig 6. the camera used in the mapping, my book and other books referenced during the project



fig 7. excerpts from my photographic study

The next step in mapping is to unravel the synthesised perception of shadow as it moves through time and space. We follow its edge as captured in the photograph. As the edge changes direction, be it due to the caster, the casted upon, or some intermediate matter, we cut the image and align it, as if the shadow never changed direction. In this moment, the world enters the state of becoming that shadows normally exist within. If the image is taken at a different time, or approached from a different angle, the result is changed, but the shadow remains the same straight line. This reversal of cause and effect generates a new understanding of a non-physical space. It instead renders light and shadow as physical and object only takes form after it is placed along the line.

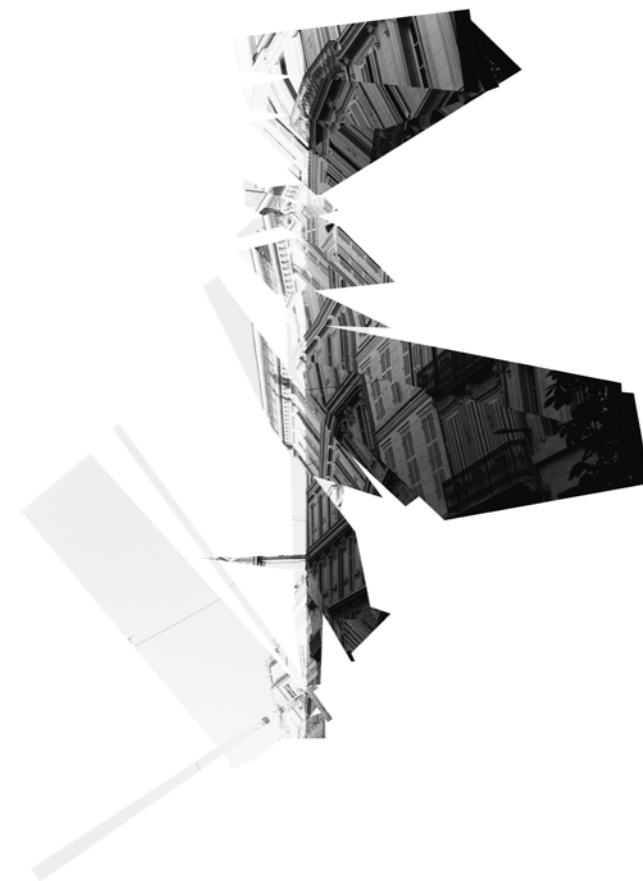
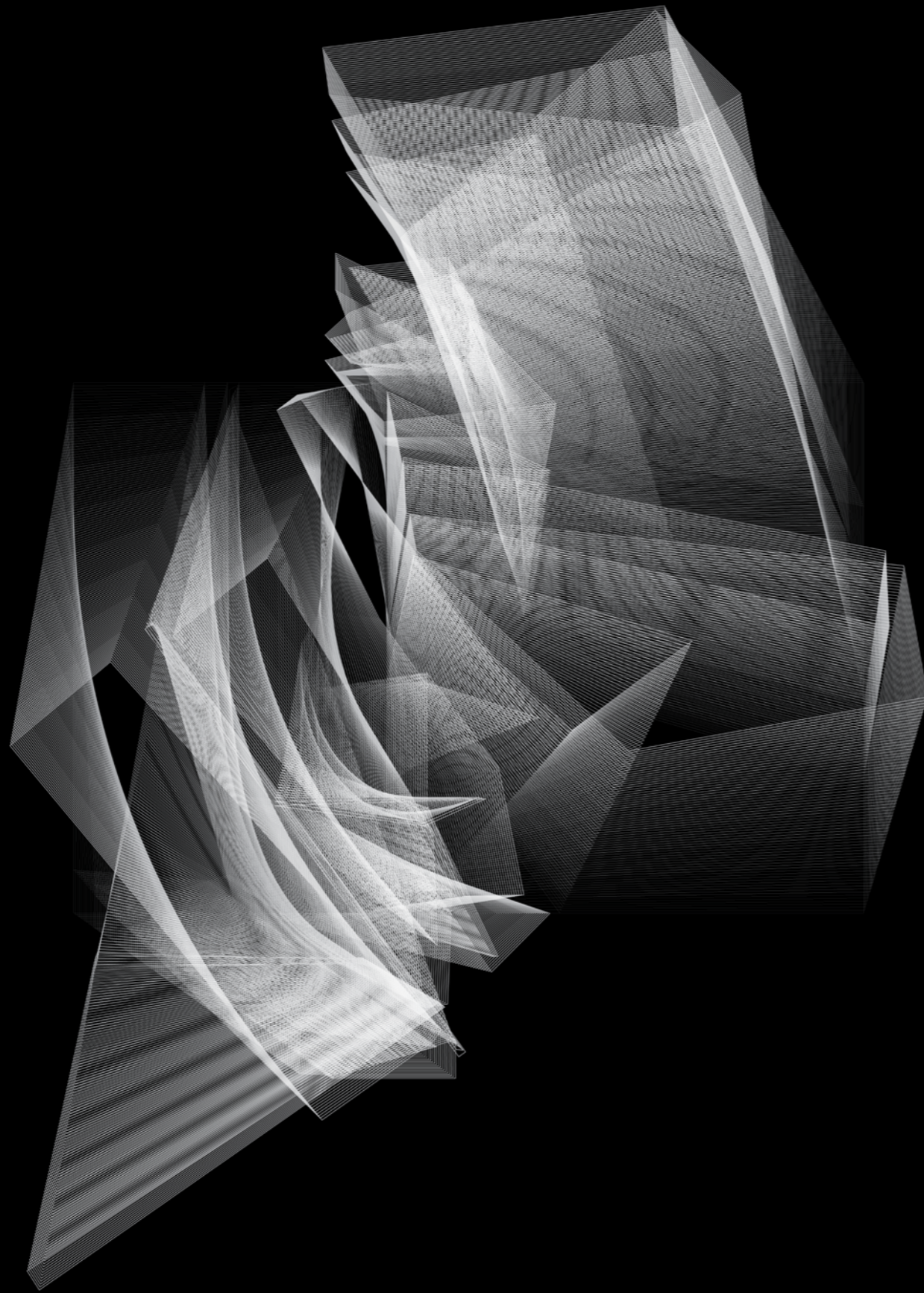

fig 8. photograph, perception ruled by matter

fig 9. cuts

fig 10. inverse Relationship, perception ruled by shadow



01_Building

Mapping these two states of being of the world, where light falls on matter, and where matter falls on light, does not inherently speak to the moment of becoming that was mentioned earlier, it only shows the became. The maps become static, a photograph and a photomontage.

To map the act of becoming the movement by the pieces of the montage is traced. Every piece is tracked through space as the photo transforms into a montage. Finally the original photo and montage are removed. Leaving us with white traces of movement, veils dancing in the dark. Between the two static and angular images lies an elegant undulating pattern.

fig 11. map of the infinite movement within the finite moment

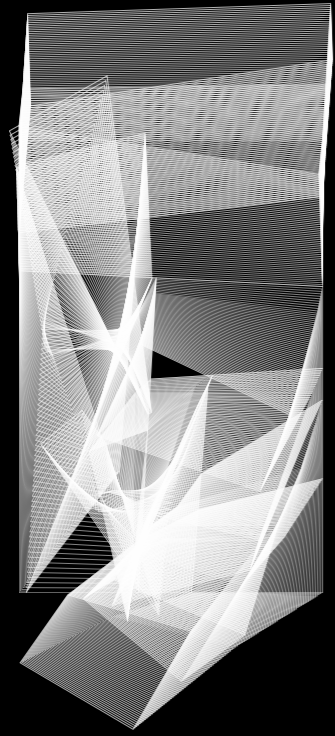

02_Rock

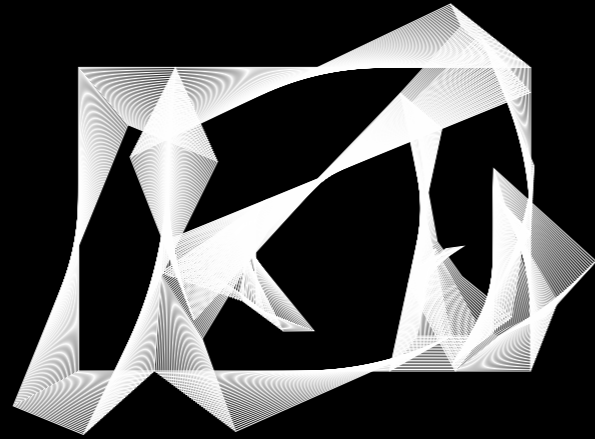

03_Wrap

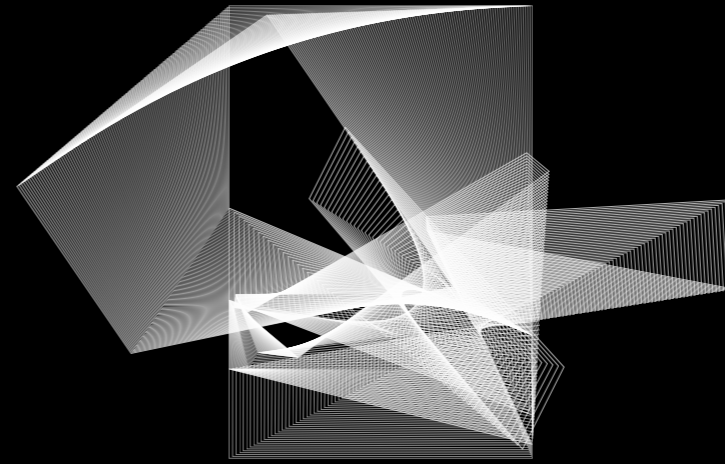

06_Fort

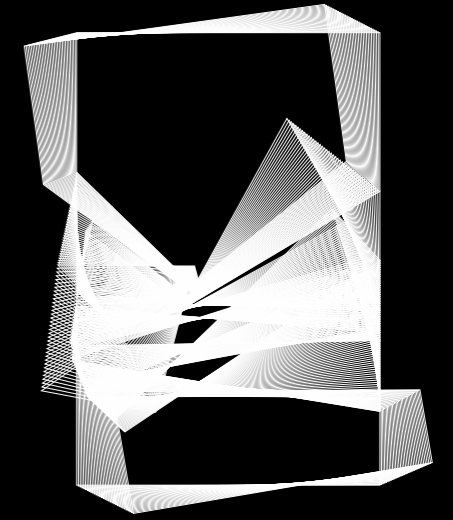

07_Alley

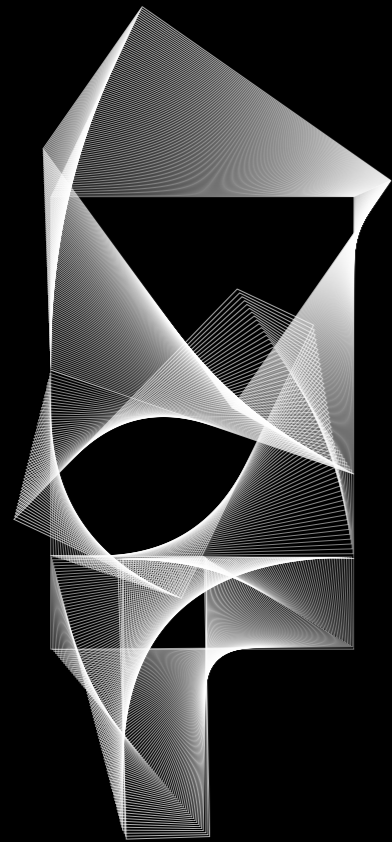

04_Dock

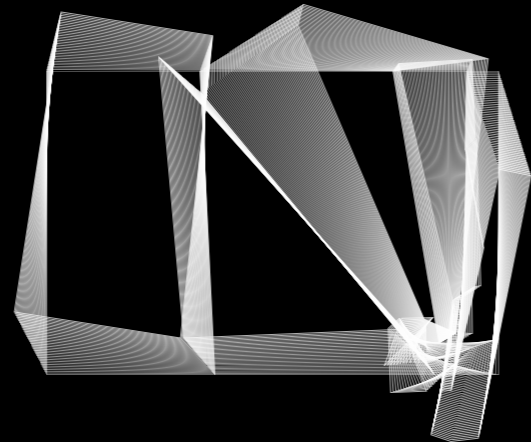

05_Plaza

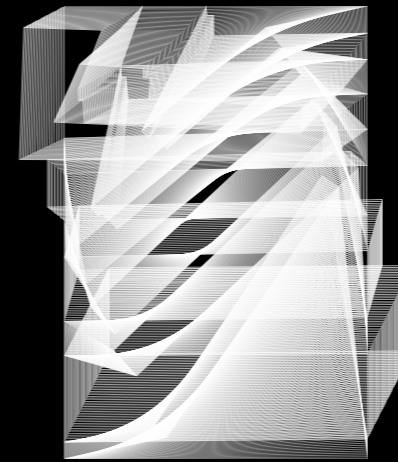

08_Stair

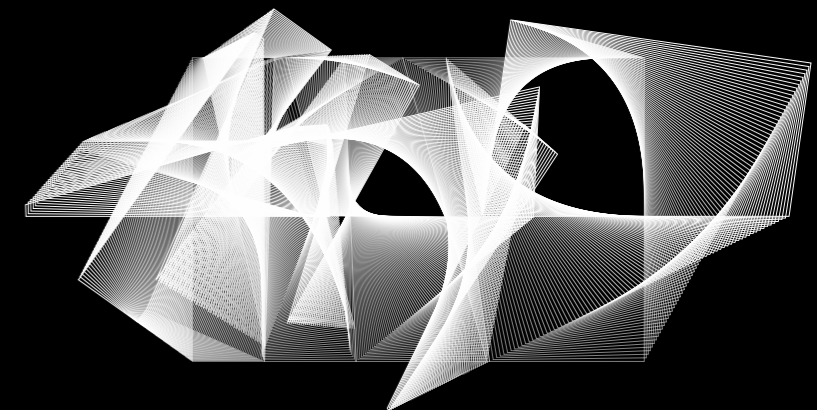

09_Facade

fig 12. maps of the infinite movement within the finite moment

The infinite movement within the finite moment inspires a new potential for architecture: to be a mediator between figure and ground. The architecture has to move away from being a polished building, leaving a resulting quarry. Instead the roles of figure and ground are reversed. The quarry is designed and the building has to be constructed with the material excavated.

The next step however, would be to remove the material in a way that it can be used to build a polished building, as well as leaving a polished quarry. At this point figure and ground would cease to exist. As the ground is carved into a figure and the figure is stacked together to become ground. The intervention as a whole then has to become a net neutral. Every gram of material removed from the site has to be added back.



fig 13, 14, 15. hand carved concrete model, exploring building with a balance between subtraction and addition

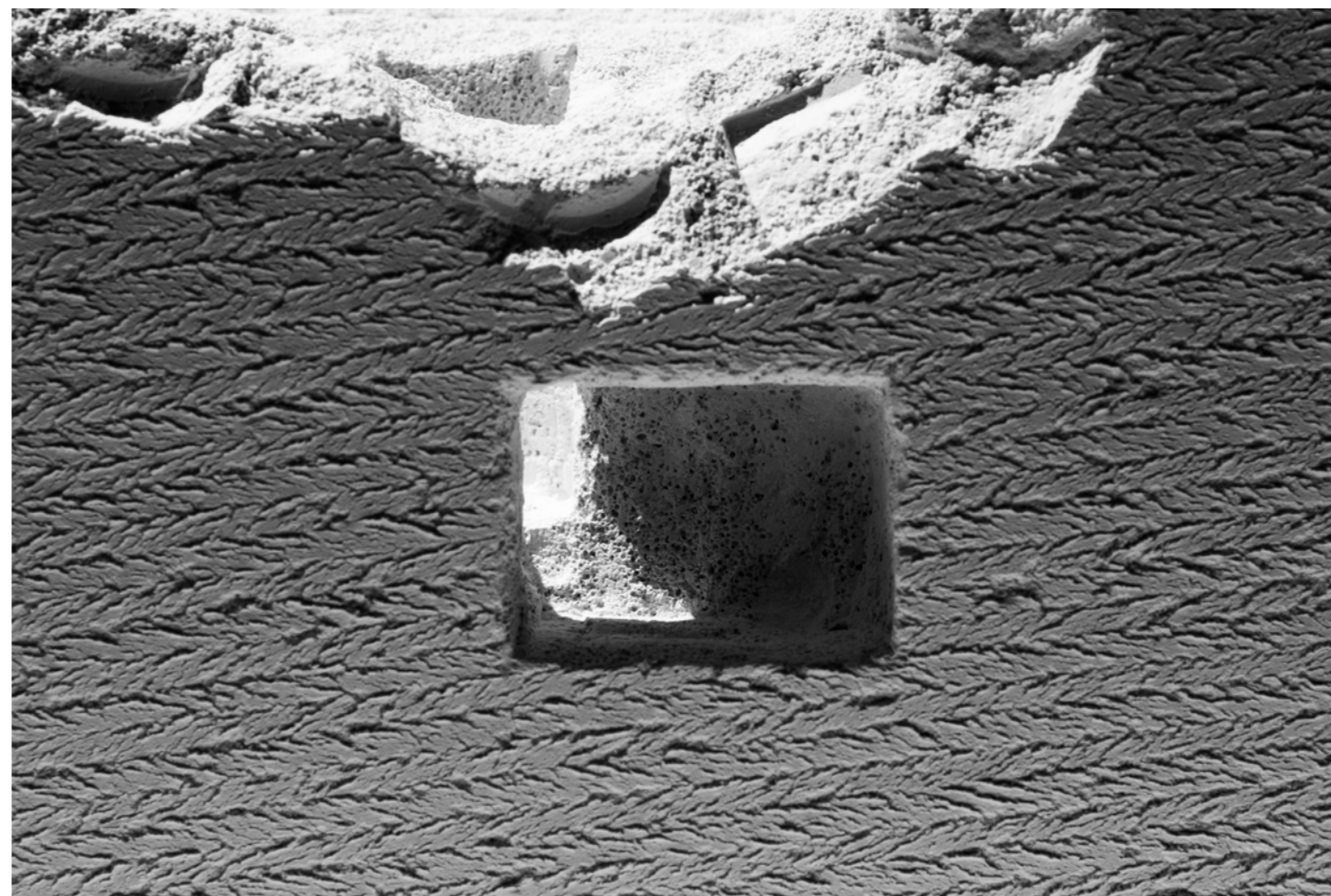
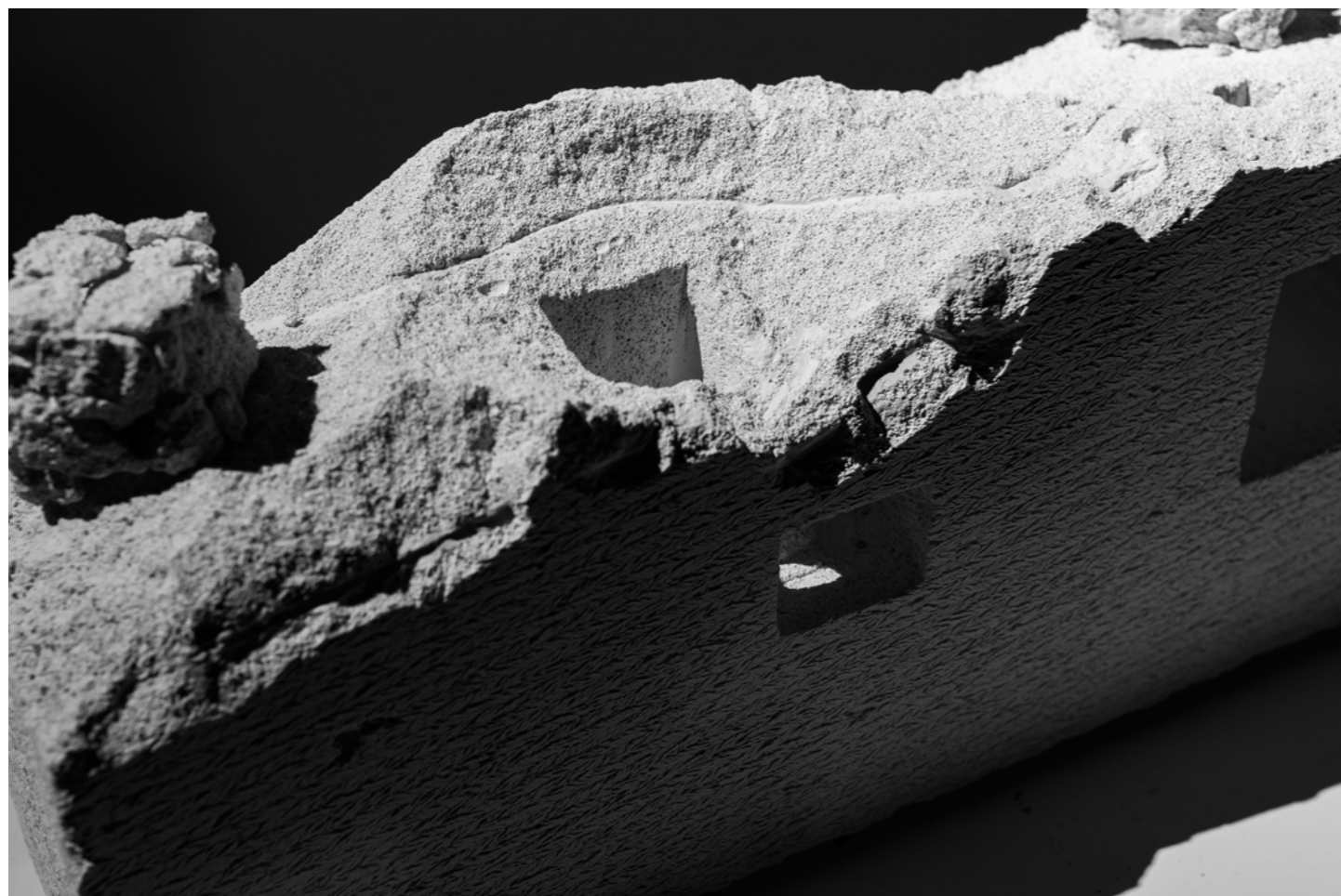

In Shadows we Boogie



fig 16, 17. cast concrete model to test the connection pattern



fig 18. final arch, previous pattern test, casting tests and 3D print tests



fig 19. waterjet cutting test



fig 20. waterjet cutting process



fig 21. waterjet cut surface marks

As seen before the intervention takes place on the Île de Ratonneau, off the coast of Marseille. This whole island is a limestone massif, meaning that there is only a single material present: limestone. This means that if the intervention were to adhere to the balance of subtraction and addition, the only materials that can be used are limestone and water.

Limestone quarries in the region use a waterjet to cut blocks from the mountains without generating waste or material wear and tear. By creating a more advanced CNC controlled waterjet of this type it would be possible to cut a precisely designed shape from the island.

This does add some constraints to the shape of block that can be cut out. The blocks need to be assembled on top into continuations of the underground spaces. Due to the lack of other materials, the connections need to be designed to be dry stacked and self interlocking. To do this an undulating cutting pattern was created, that in section is always a straight line. Since the waterjet can move and rotate, but it cannot bend.

Theoretically this all works, however the best way to test the feasibility of this was to just build it (in a smaller scale). To test this I built a concrete scale model and assembled it without the use of any glue or fixers of any kind. The dry stack, self interlocking connection works, if the material is heavy enough.

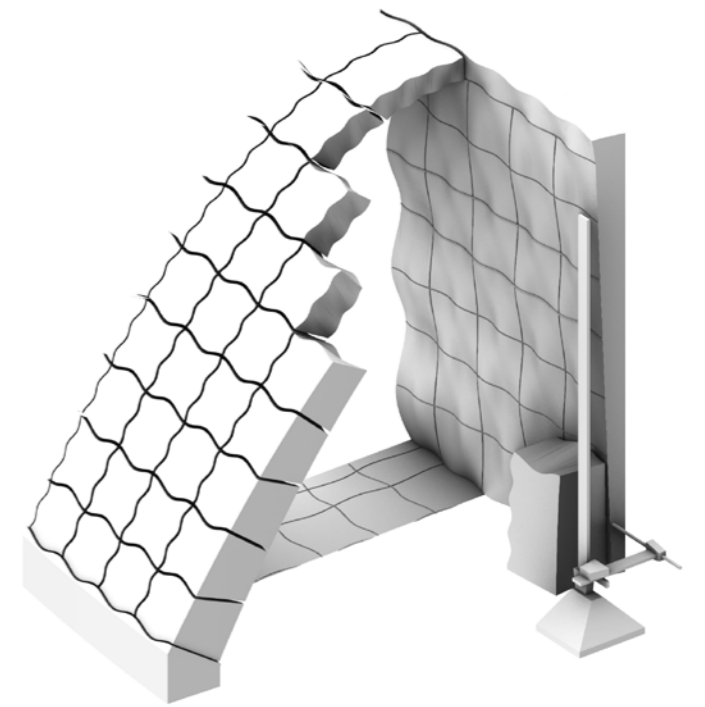
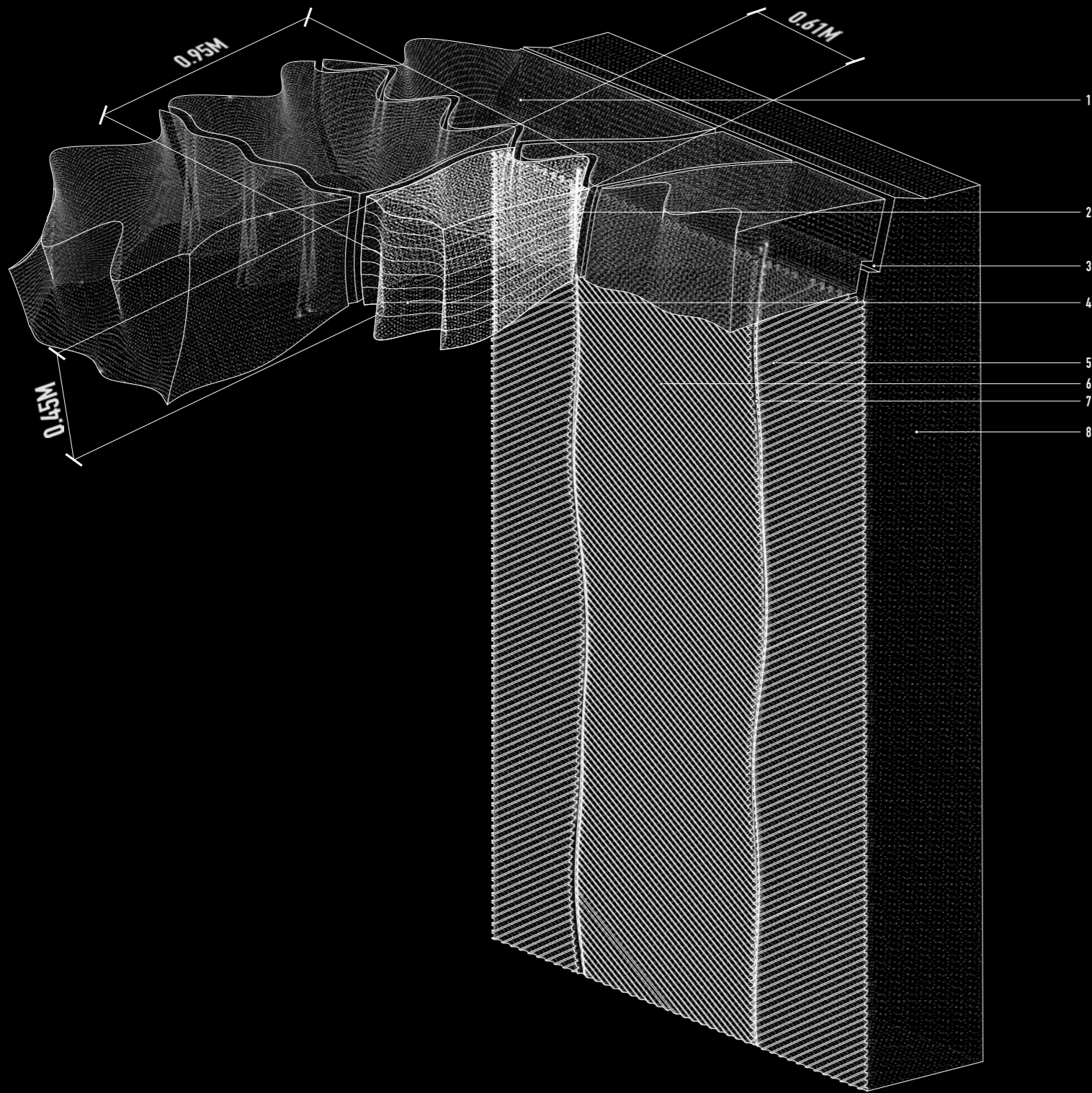

fig 22. diagram of the CNC waterjet cutting a block underneath a built arch

fig 23, 24. details of the connection between addition and subtraction in the arch



- CNC-WATERJET CUT LIMESTONE BLOCK 1
- SINGLE CURVED INTERLOCKING PATTERN (HORIZONTAL) 2
- CARVED TOP ARCH COMPRESSION CONNECTION 3
- SINGLE CURVED INTERLOCKING PATTERN (VERTICAL) 4
- INTENTIONALLY EXAGGERATED WATERJET FLUTING (TYPE 1) 5
- INTENTIONALLY EXAGGERATED WATERJET FLUTING (TYPE 2) 6
- CUT LEFTOVER CHANNEL FOR CONDENSATION COLLECTED THROUGH TYPE 1+2 7
- GROUND // LIMESTONE MASSIF 8

SCALE 1:5

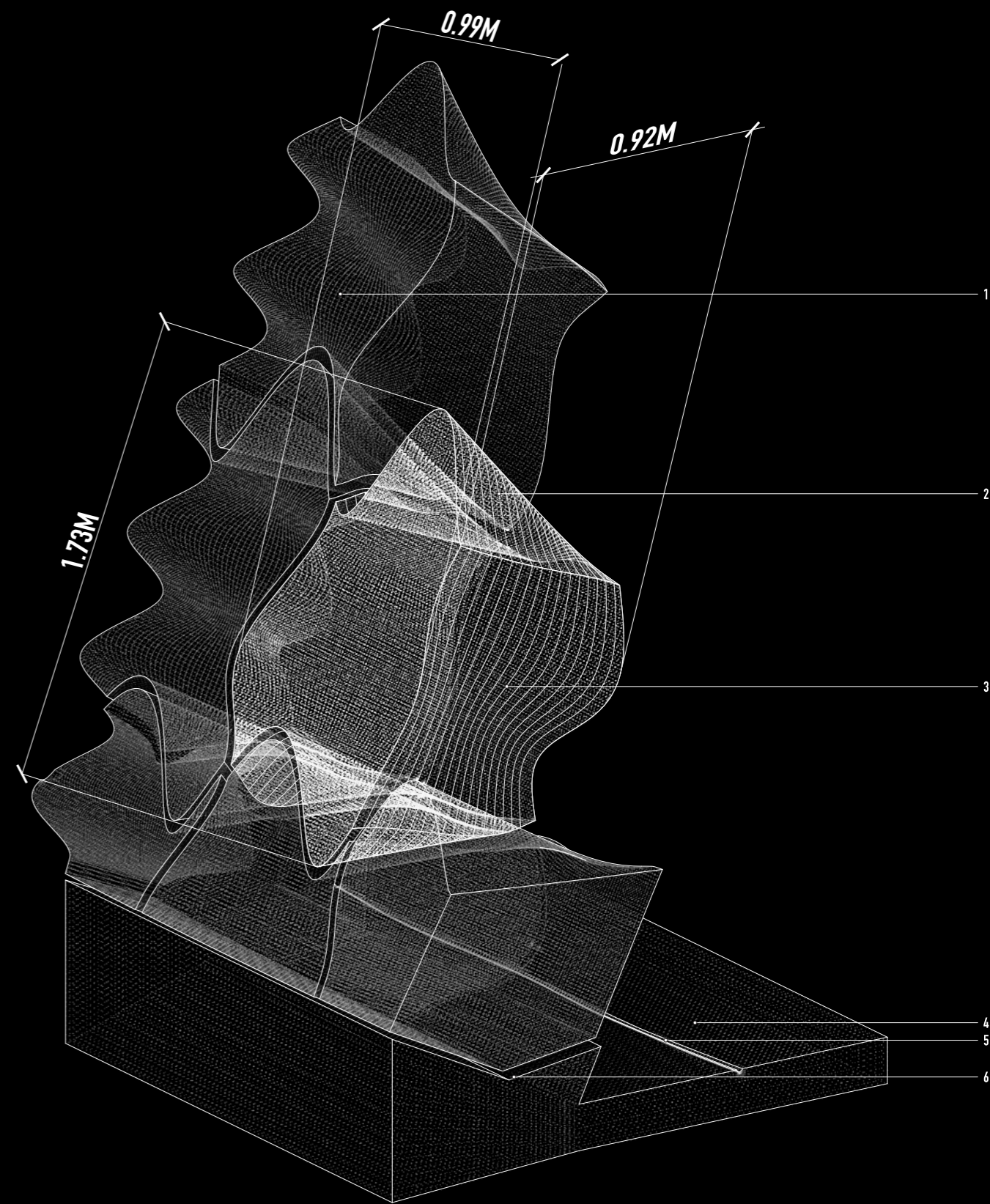

- CNC-WATERJET CUT LIMESTONE BLOCK 1
- SINGLE CURVED INTERLOCKING PATTERN (HORIZONTAL) 2
- SINGLE CURVED INTERLOCKING PATTERN (VERTICAL) 3
- SLOPE TOWARDS 'WET' SPACES 4
- CUT LEFTOVERS FUNCTION AS DRAINAGE CHANNELS 5
- FOUNDATION CONNECTION CARVED IN GROUND 6

SCALE 1:5

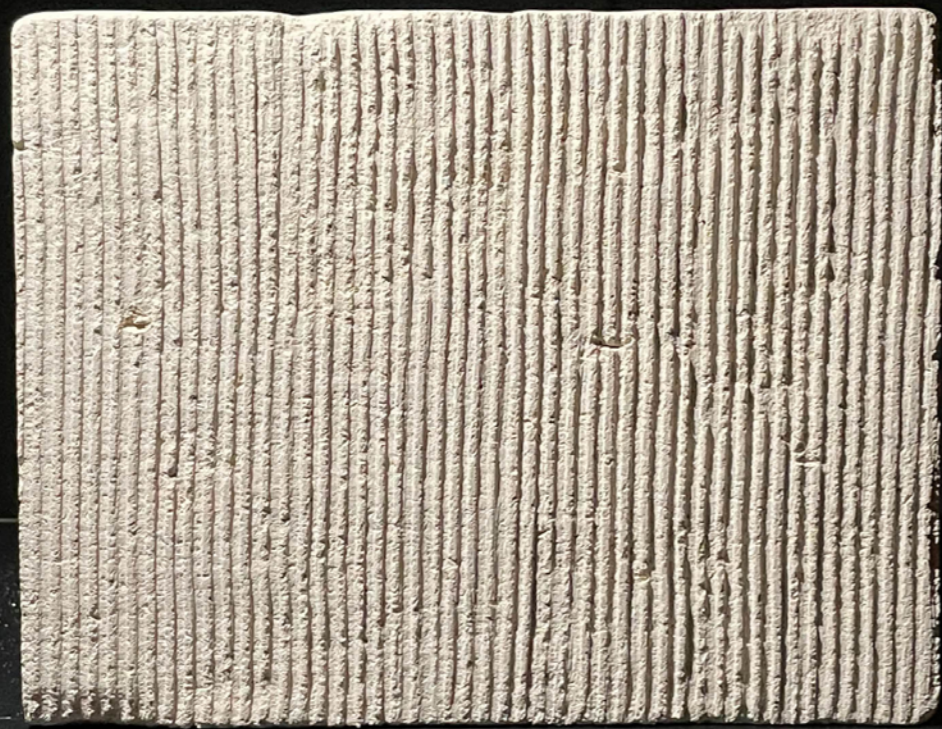

fig 25. 1:10 Limestone study, the surface finish of an intentionally 'wrong' waterjet cut



fig 26. 1:1 Limestone study, the surface finish of an intentionally 'wrong' waterjet cut

Since all material subtracted has to add to the addition without changing phases there is no grinding to dust, polishing or any other postproduction after the blocks are taken from the ground. The additions had to be carefully designed together with the subtraction to ensure there was both a balance in volume, as well as a balance in the type of block extracted. Since every intervention has to cancel itself out below and above ground.

The surface model shows both the volume added on top, as well as the volume subtracted below. The mirror surface below showing the underside of the model without needing to bend down to it.

When planning the two final models I realized that carving the final model of a single space from limestone would leave me with a lot of dust. This dust could have been thrown away, however it could also be used to cover the 3D printed model, to make the colour and material of the two models coherent, as well as incorporate the concept into the act of modelmaking.

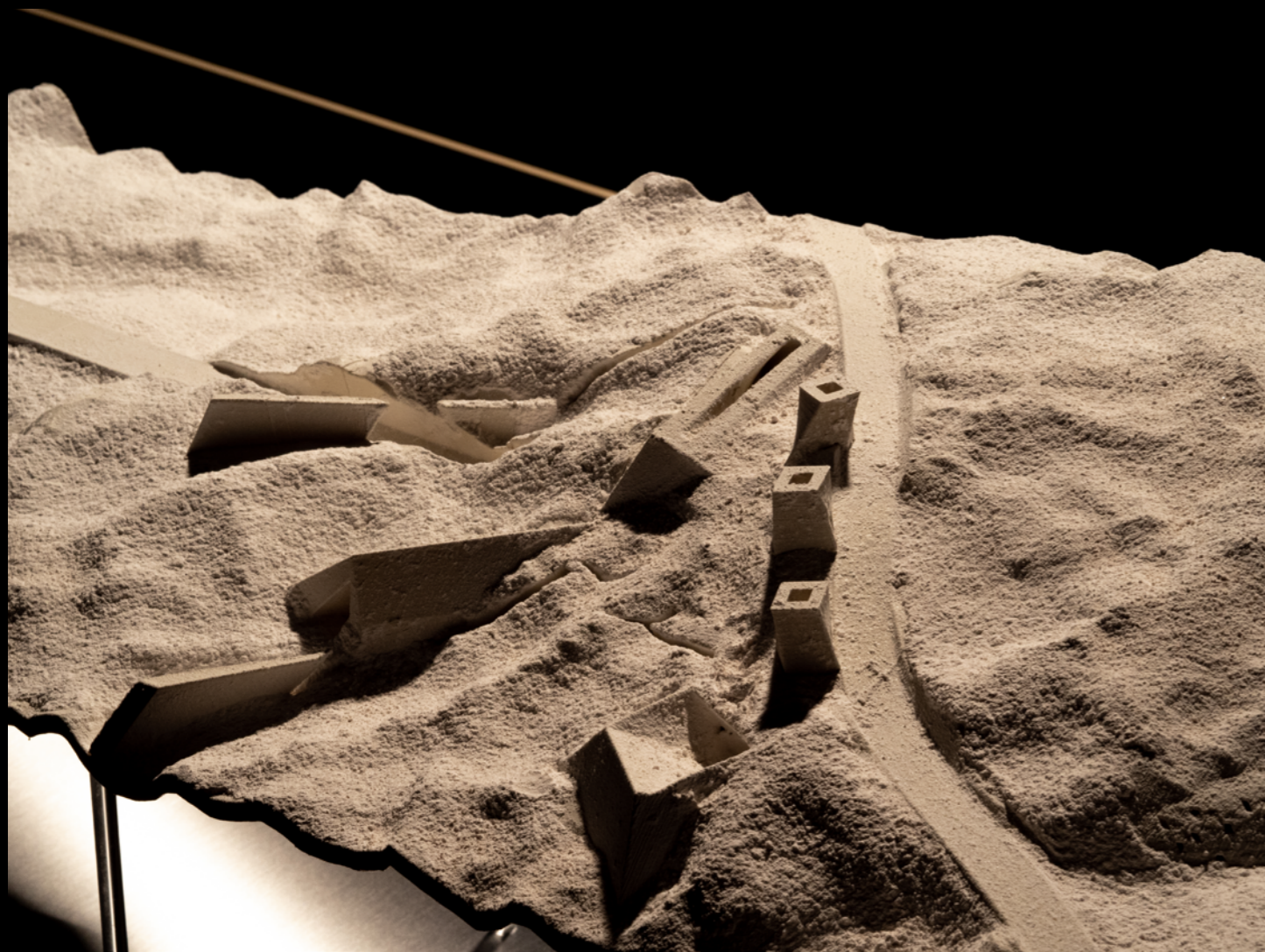
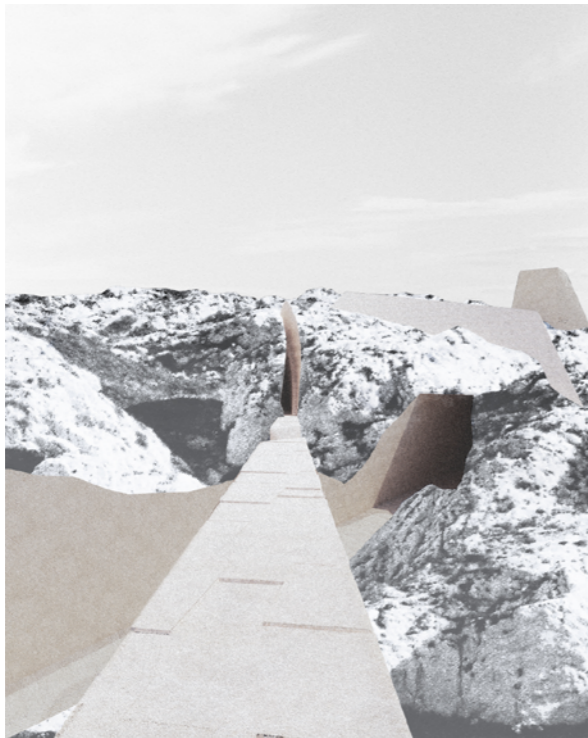
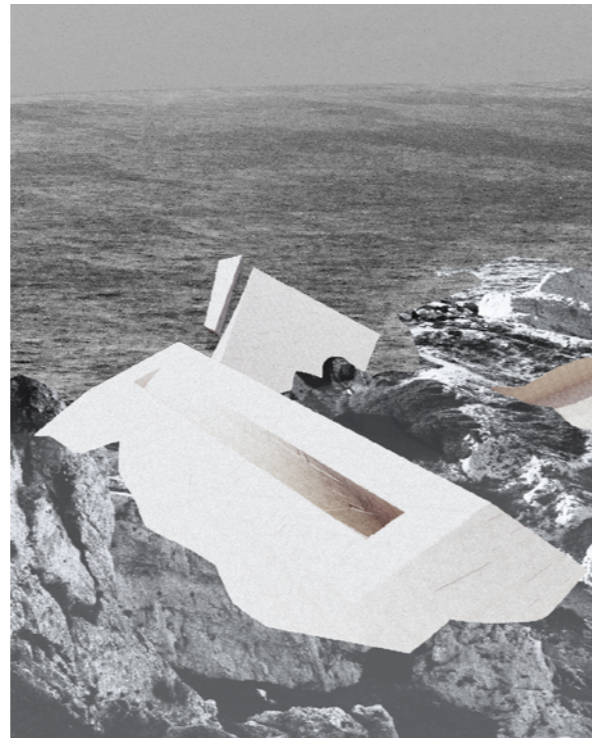

fig 27, 28. site surface model (1.2m x 0.2m), stainless steel base, perspex stick structure, 3D print covered with limestone dust from sculpture model



Canyon



Linear



Line

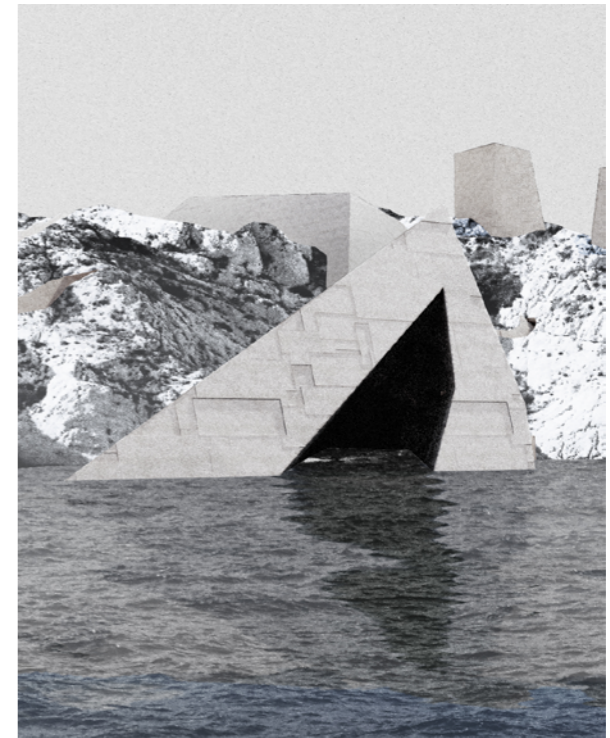

Reflection



Cliff



Aperture



Upwards



Wall



SCALE 1:200

fig 30. 1:200 projected floor plan, due to the non cartesian nature of the intervention it is a collage of 12 different height floor plans

Due to the Non-Cartesian nature of a project following from the dancing logic of space the spaces are difficult to describe in floor plans and sections. Due to this problem a number of animations as well as this model were made to explain the space and connections clearly. In the end the idea of the floor plan and section had to be redefined to make them fit the project. In case of the floor plan it is a montage of 12 different elevation floor plans. Weaved together to show how one would perceive the route through the intervention.

The section is a composite of 8 different sectionplanes, that are not all planar, stitched together to show how one would experience the differences in depths and heights throughout the intervention. As the concept of this intervention comes from moving between states of being, remnants of the intervention as it would appear in the background of the different section planes are left behind. Indicating that the experience would not actually be perceived as linearly as it is implied when reading the section as a conventional one.

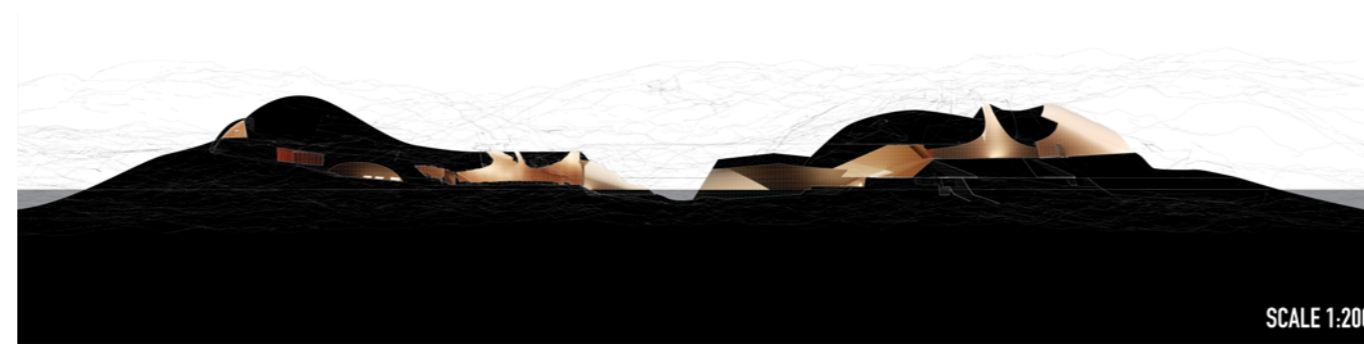

fig 31. 1:200 composite section, whole section zoomed out overview

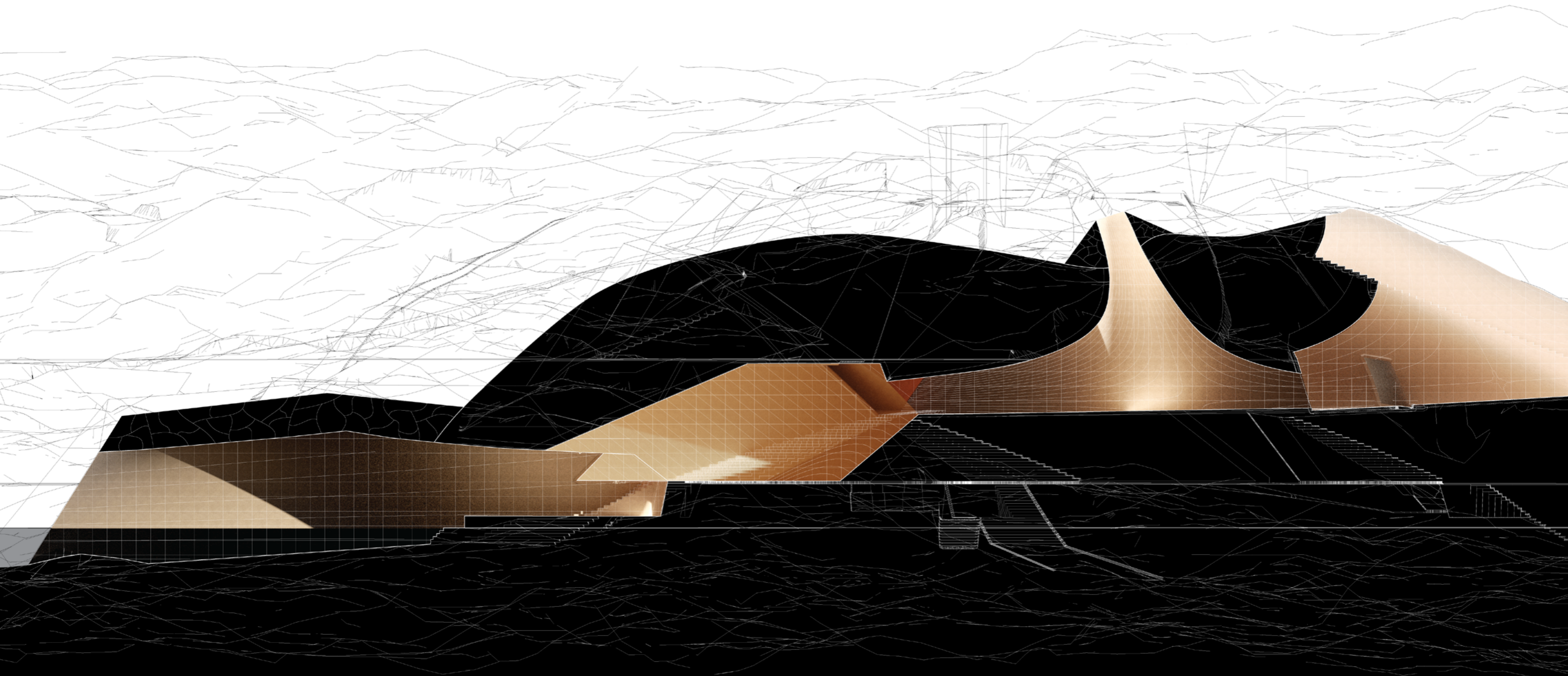
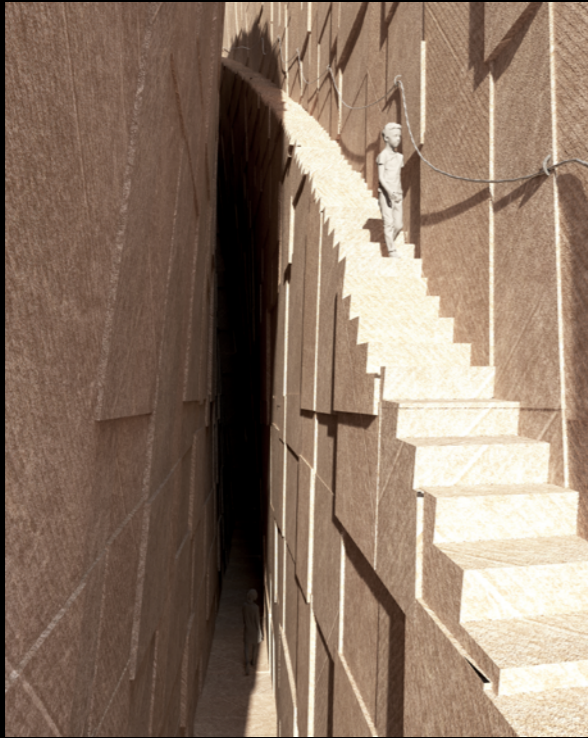

fig 32. 1:200 composite section detail

fig 33. Subtraction view of the eight spaces



Canyon



Linear

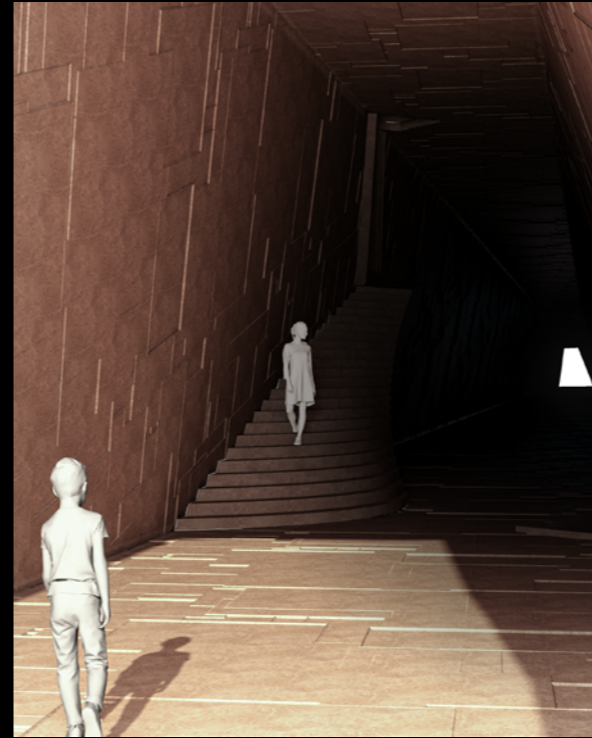

Line

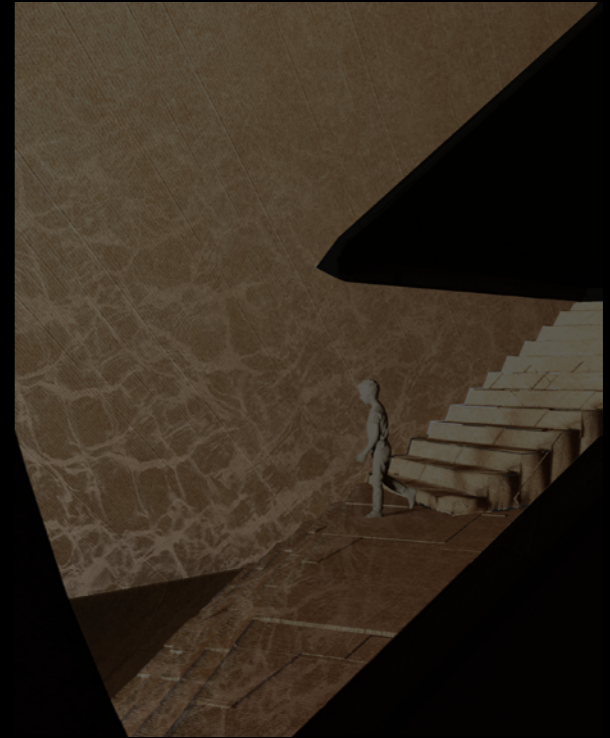

Reflection



Cliff



Aperture



Upwards



Wall



block with 3D printed drill guide



drill the non-planar surface



theoretically split



splitting



physically split



before mass subtraction



subtraction (different block, same process)



addition carved, model scale too small for addition



mass finished, surface finishes and cleaning left



state of every surface during the process

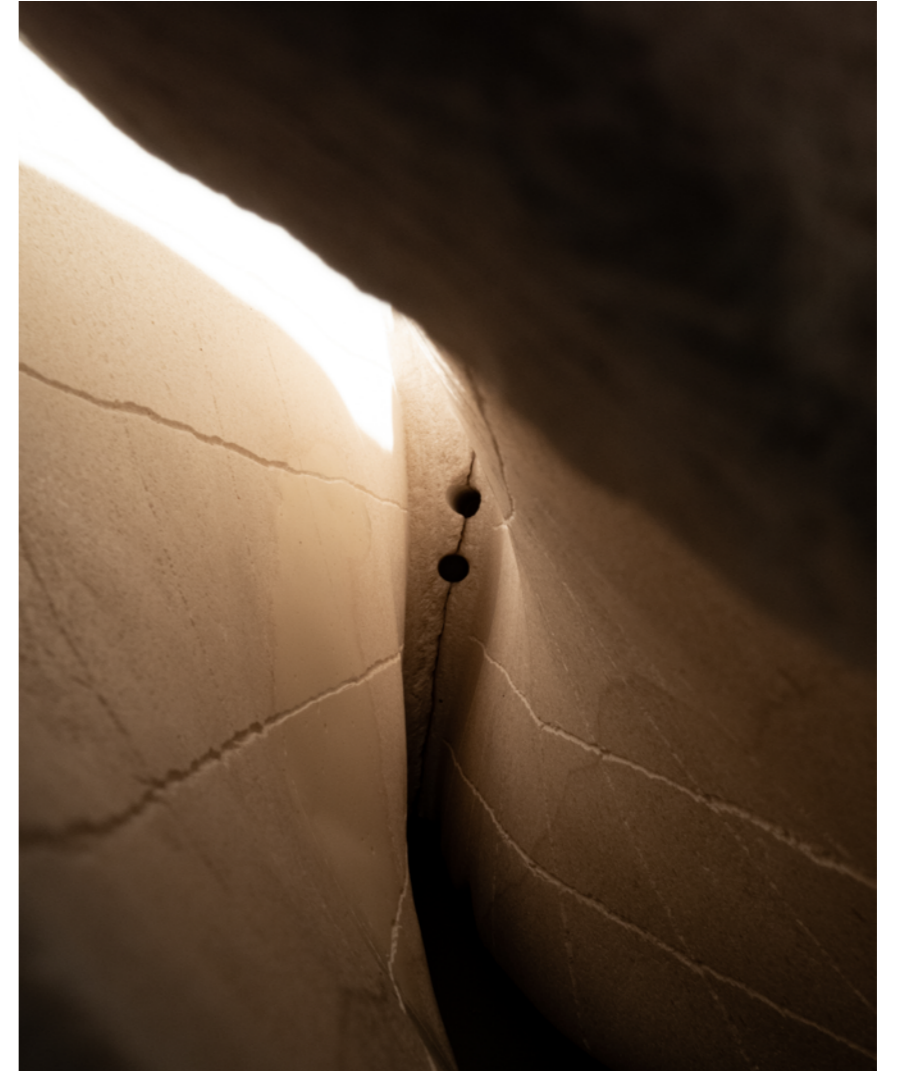
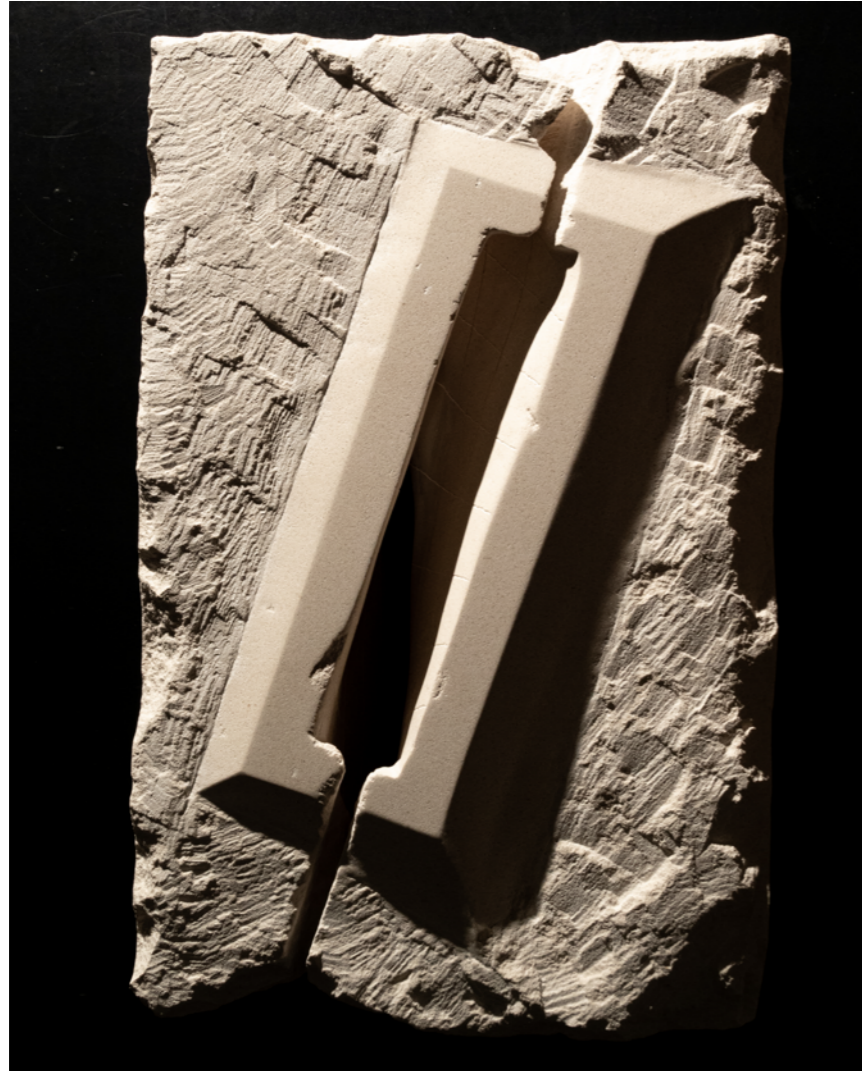

Anomalous Marseille

Marseille through two lenses, the Border and the Territory
TU Delft | Academic | 2021

The initial phase of the BT Graduation studio is a group work mapping exercise which takes somewhere between 10 and 20 weeks. The aim is to create two maps through which a new understanding of a city, in our case Marseille, is created. This can then become the basis for the individual graduation project that follows. There are two maps: the Territory map (1.5 x 1.5m) and the Border map (3.6 x 0.9m).

Anomalous Marseille | Territory Map

Confronted with the multiplicity of possible interpretations and readings of Marseille's underlying workings and relationships, we decided to undertake a compound strategy that would yield the direction of our collective analysis of the city. Approach unfolded from initial observations; the first noticeable characteristic of the city, its relative otherness, albeit not only with regards to other parts of France, but more importantly its structural propensity to undergo 'othering' of its elements. Marseille is composed of various distinguishable spaces — or patches — with properties, in relation to each other and the rest of the city, are somewhat, 'weirdly' emphasised. As one of the biggest port cities of Europe, it represents a heightened transitional character. As people, ideas, beliefs or technologies travel through, they imprint, in one way or another, on the urban fabric.

We put all the observed heterotopias into the same 2-dimensional space, which in our case was a wall. Parallely, an atlas that contains contextual information about the anomalies is developed to keep track of the abundant data we gathered. We then experimented with their positioning, relating one to another, finding connections and their extensions which, we hoped, will tell us more about the territory and instigate the process of noticing, distinguishing and analysing their border conditions. The process is therefore reversed in our case.



In collaboration with:

Agnieszka Omastka
Ewa Ziemiecka
Gan Liu
Raneem Nahawandi
Shaghayegh Vaseghi
Sun Ah Hwang
Weiming Yin
Yifei Zhang
Zofia Sosnierz

fig 1. anomalies from a satellite view

It was then when an epiphany was reached; the connections between the anomalies that we sought to find did not feed into our redefining of Marseille neither as a heterotopia in itself nor as a collection of heterotopias, for it repetitively circled us back to the established systems and clichés of the city. Instead, we turned to studying the physiognomies that trademark the 'anomalies' as anomalies to experiment if we could reconstruct the image of Marseille in a way that is comparable to Canaletto's depiction of Vicenza and Braque's depiction of the violin and palette.

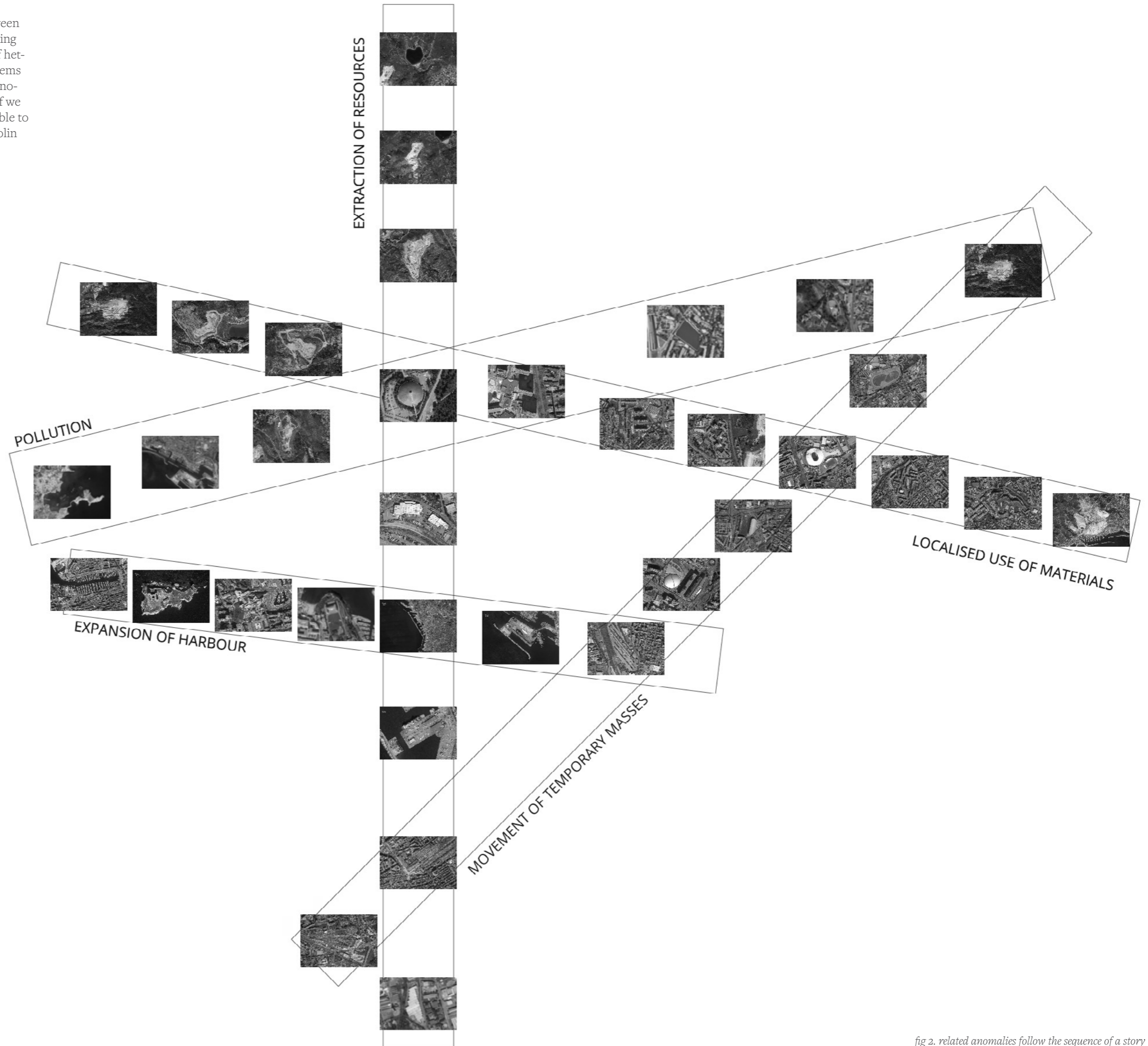

fig 2. related anomalies follow the sequence of a story



Reflecting back on our Foucauldian thoughts, it must be remembered that Foucault interprets the city in such a way that we can see the fragmented realm of the urban space as one of opportunities and freedoms, as one in which 'otherness' becomes a real possibility. Our study therefore shifted to depicting the 'othernesses' of Marseille with which its spirit and (city)sphere is dominant, and distinguish their individual relevance and interdependence within the various processes of the city. The refocusing of our study called for additional research methods. We further developed our findings into abstractions, leaving behind only the most characteristic anomalies of each heterotopia. The image of the city is subsequently restructured with its founding based on the causality found within its constituent elements through an oligopolistic lens, precipitating five dominant workings and systems of the city: (1) the expansion of the harbour, (2) extraction of resources, (3) localised use of materials, (4) the movement of temporary masses and (5) pollution.

The overlapping of processes is inevitable, for some anomalies are affiliated to more than just one system. Where there is plurality in urban significance, its illustrative representation is also varied. The multiplicity in the ways of interpreting the city through an oligopolistic lens on the other hand results in this map which can be read from every direction. An atlas of anomalies is placed on each corner of the map, containing the original satellite view of all anomalies, as well as their individual story. The atlas, then, comes into play if the viewer wishes to decipher what they see, a very much voluntary participation with the map.

fig 3. Anomalous Marseille - The Territory Map

The question emerged of what would be the best way to understand and investigate the separation between the industry that sustains Marseille and the living city. The line separating the two was drawn, it represents the border but also the path we took to explore this separation. Initially, satellite imagery was used to explore the problem, then more first-hand experience helped us to confirm our findings. We were thus strolling along the border, trying to make final adjustments to our map. Google street view helped us to prepare the first draft before going to Marseille. The tool was undeniably useful, yet it largely flattened our research. That is to say, since it only includes imagery, the visual aspect of the border was prioritised. Site visit which followed the first draft enabled us to focus on other, non-visual, conditions of the border. Thus, we explored things like sound, pollution, site's temporality or absence of light.

Following the previous demarcation of the border between the zones, we decided our map would take the form of a straight line enhanced with a notation system enabling us to record our findings from the border zone. We thus proceeded to the unfolding of the path. Satellite images were cut and reassembled. Various attempts were necessary, and a series of iterations to achieve the desired result. It was furthermore necessary to decide on how much information, on each side of the border, are we including. Each of us, therefore, marked the area of interest (see the image above). This aspect was altered many times and in the end, the zone around the border was largely reduced.

fig 4. the border between the residential and industrial Marseille

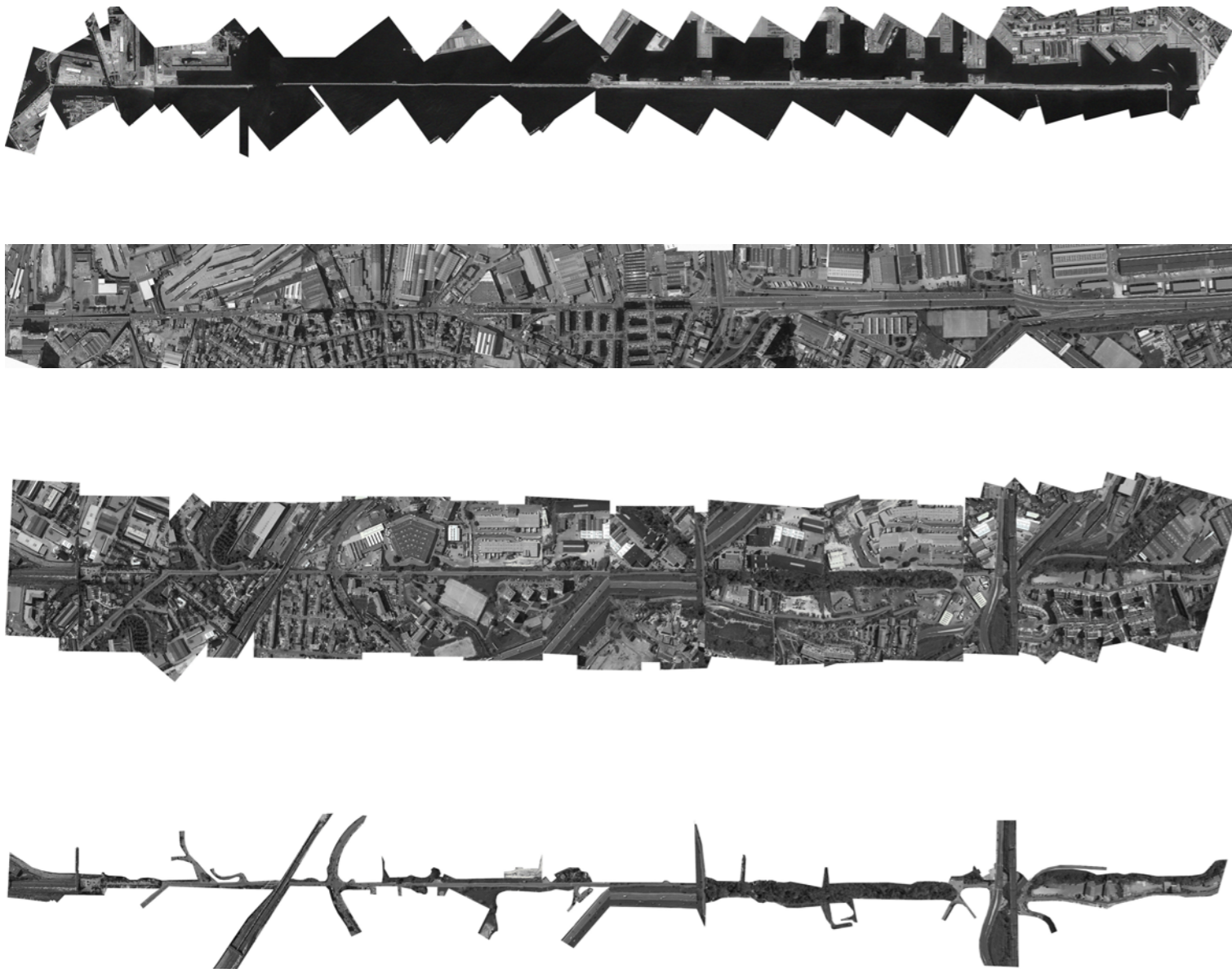
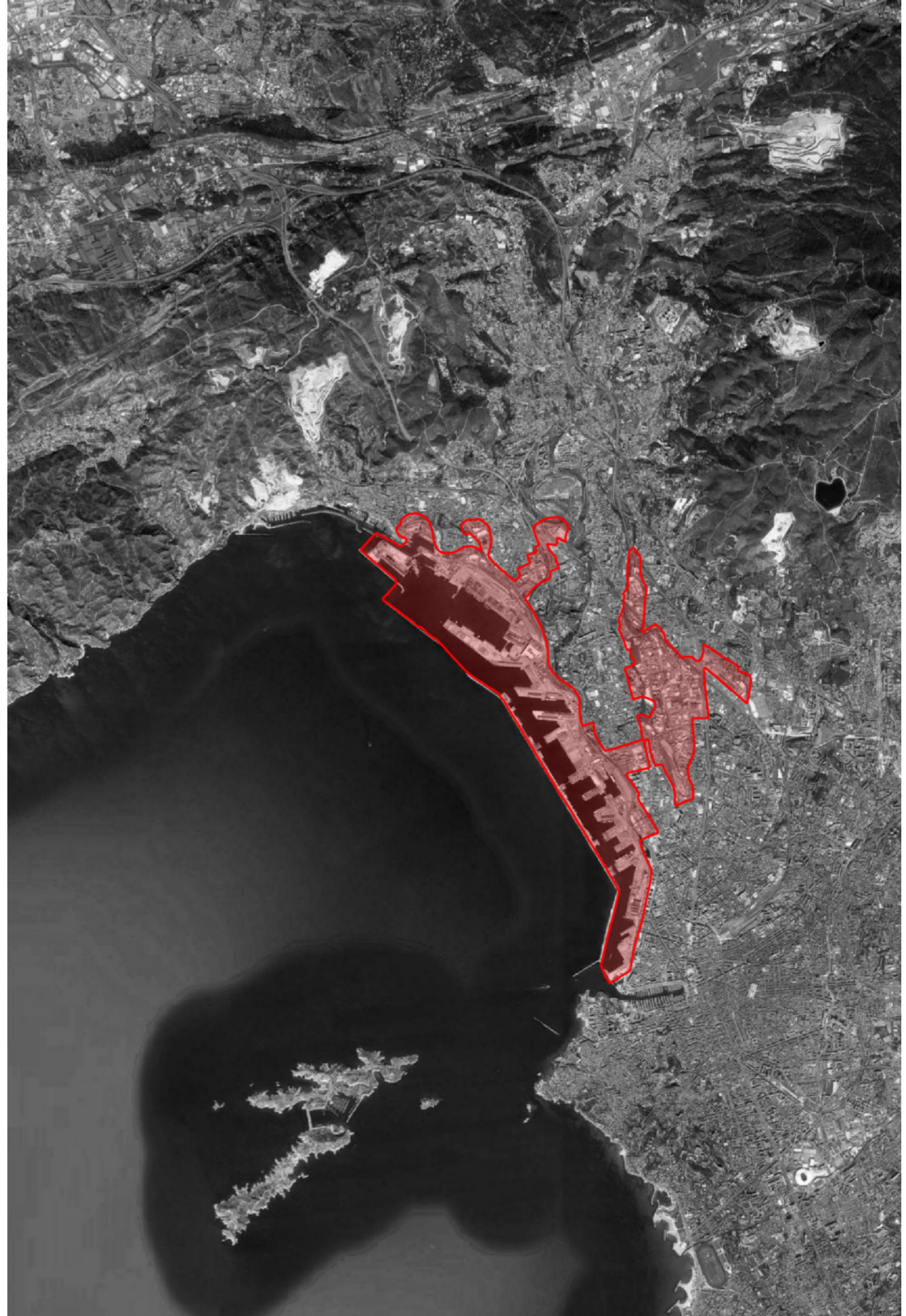
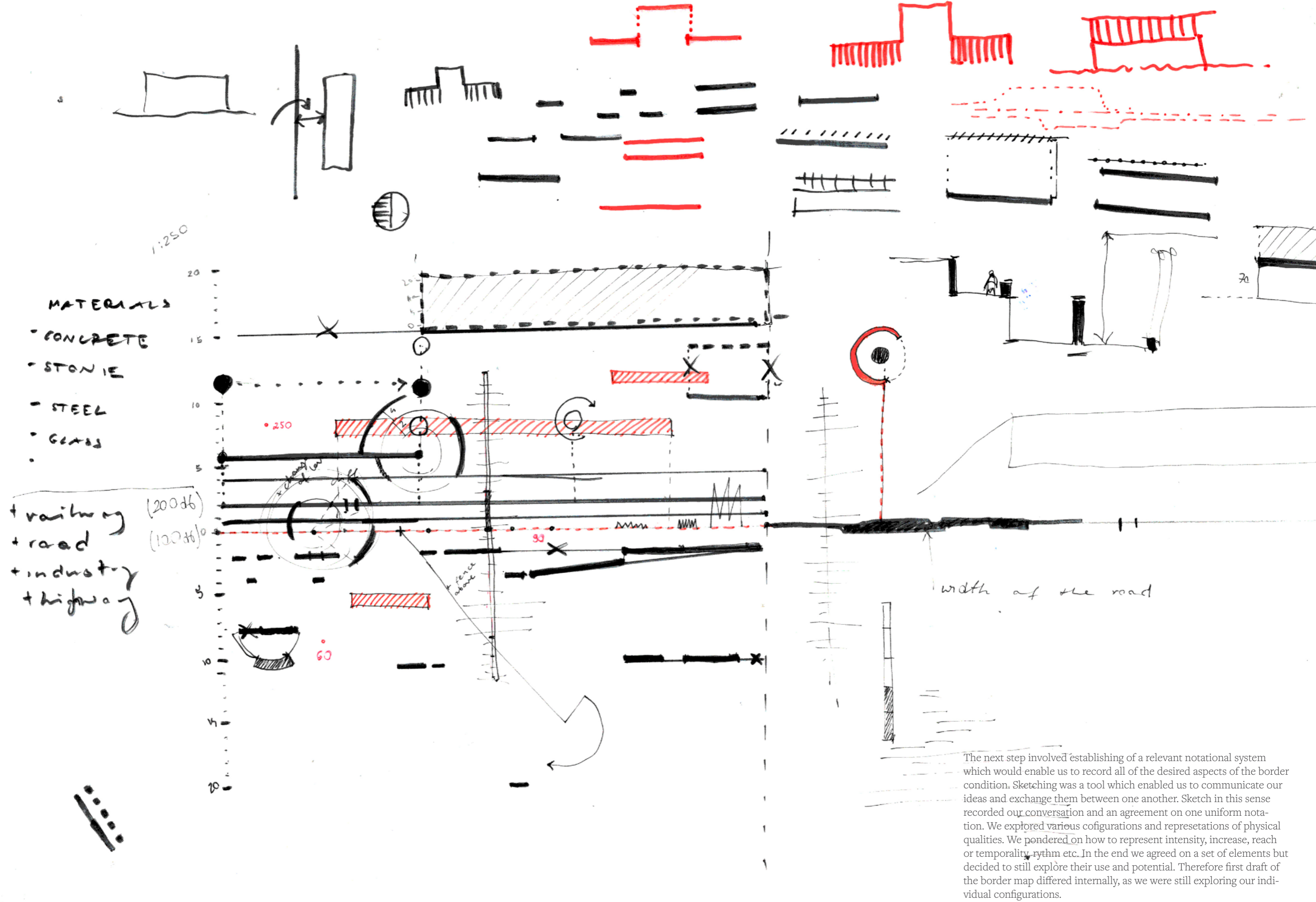

fig 5. straightened strips of the border



The next step involved establishing of a relevant notational system which would enable us to record all of the desired aspects of the border condition. Sketching was a tool which enabled us to communicate our ideas and exchange them between one another. Sketch in this sense recorded our conversation and an agreement on one uniform notation. We explored various configurations and representations of physical qualities. We pondered on how to represent intensity, increase, reach or temporality, rhythm etc. In the end we agreed on a set of elements but decided to still explore their use and potential. Therefore first draft of the border map differed internally, as we were still exploring our individual configurations.

fig 6. testing notational systems

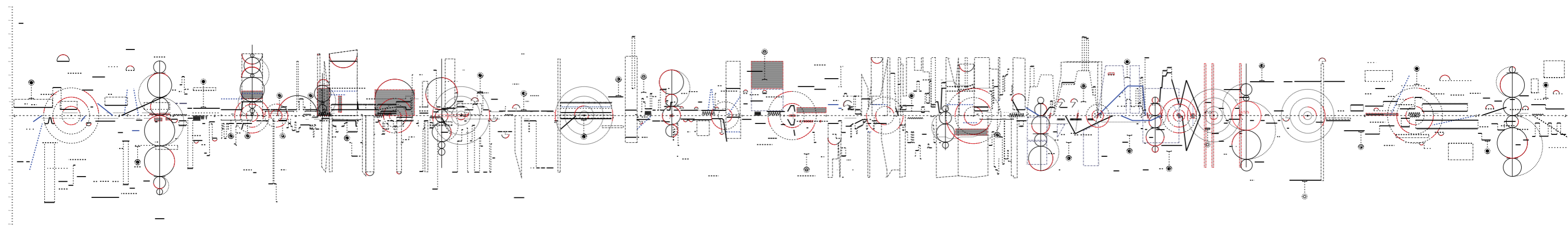

fig 7. A Threshold Within the City - The Border Map

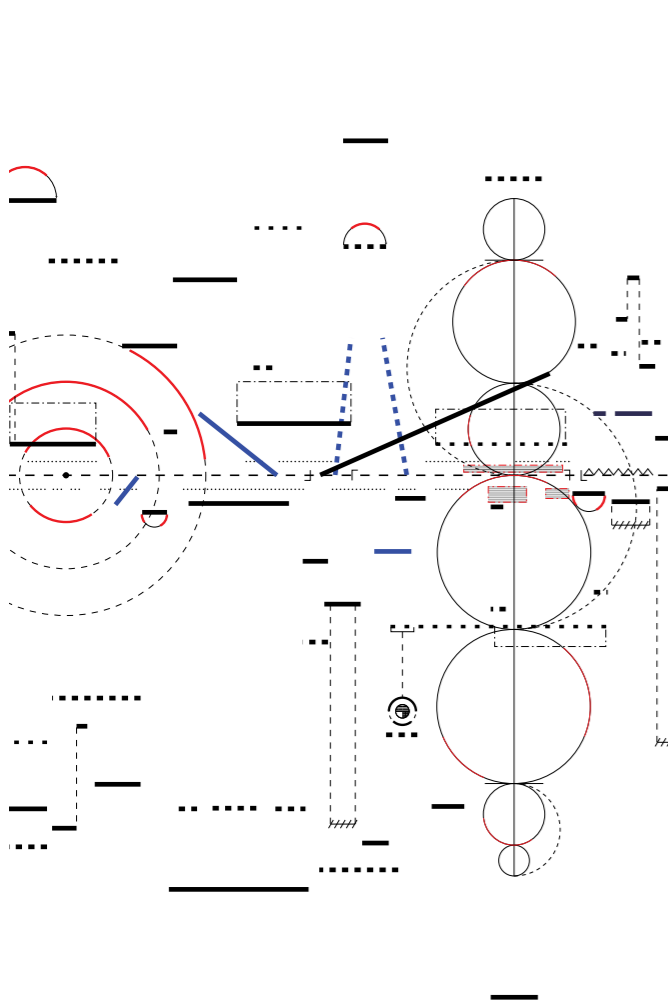

fig 8. zoomed in excerpt, photo of the corresponding part of the border.



No More Shadows

Experiencing the aesthetic of destruction
The Last Nuclear Bomb Shelter | Competition | 2020

The defining visual trait of a nuclear explosion is the double flash. No other light source can be as bright as a nuclear bomb and have this characteristic. As the explosion starts the bomb is heated to temperatures around 10,000,000K this superheats the air around it, causing it to emit light, FLASH 1. The shockwave from the explosion then smothers the light by becoming opaque, explaining the brevity of the flash. The shockwave at this point is still close enough to not have touched anything around it. As the shockwave travels out it becomes colder and thus more transparent, allowing the light out again. This flash lasts much longer and has a more diffuse nature due to the size of the source, FLASH 2. The full energy of the terrible weapon is now released and everything around it is destroyed.

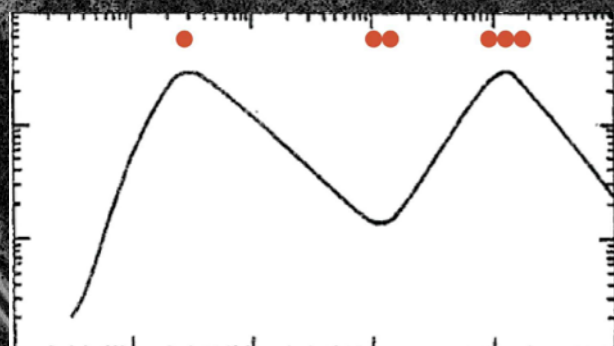

fig 1. plan superimposed on Nevada Test Site



Experiencing the reaction

The monument takes the visitor through the stages of the explosion as if witnessed when there. You arrive through the hauntingly beautiful cratered landscape of the Nevada test site to find three inverted craters surrounding a courtyard with a central crater. When you enter the building you step inside a bright hallway, on your right hand information about nuclear weapons and the devastation they cause, on the left a glazed view towards the courtyard.

The first dome contains a central bright pointlight and human figures casting long sharp shadows all around. Signifying life still going on at the time of the detonation and FLASH 1. The second dome is flooded by bright light from a large, diffuse source, FLASH 2. The only remains in the room are the hazy nuclear shadows of the people that once were, the spots of the ground that were not burnt by the explosion due to the human shield. The final room takes you back to the moment before it all happened. The nuclear bomb hanging from a cross under its own halo, depicted as a divine intervention. The saviour that stops wars and declares victors. But at what cost?

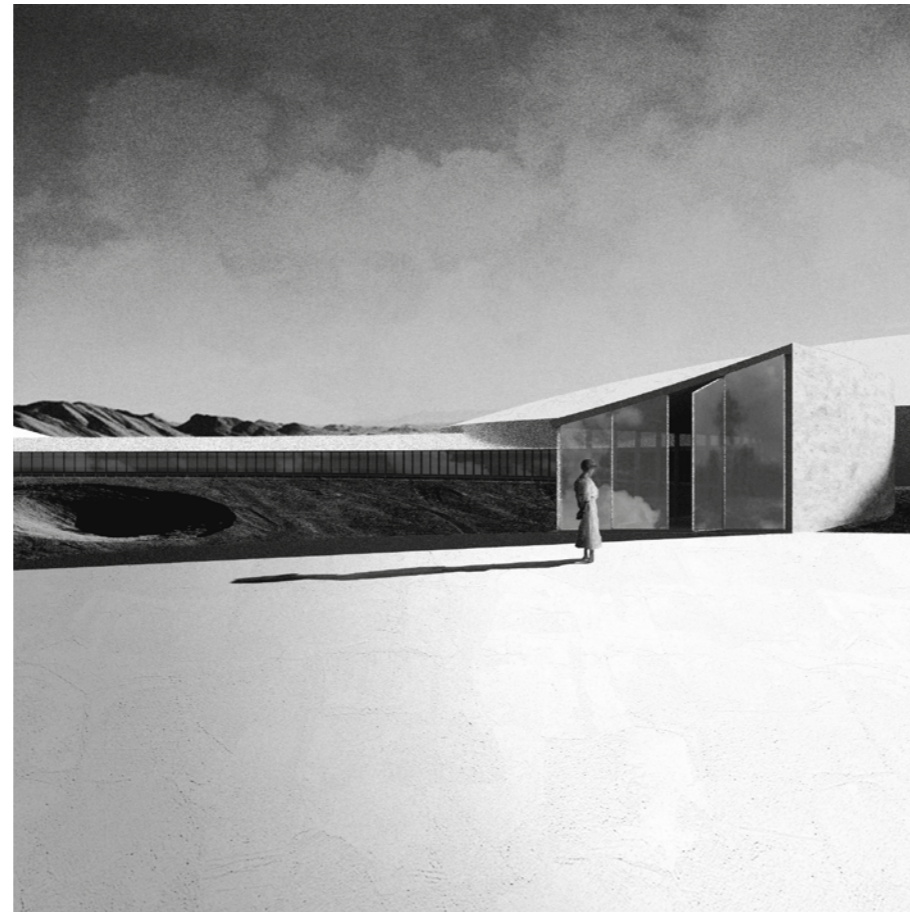

fig 2. entry

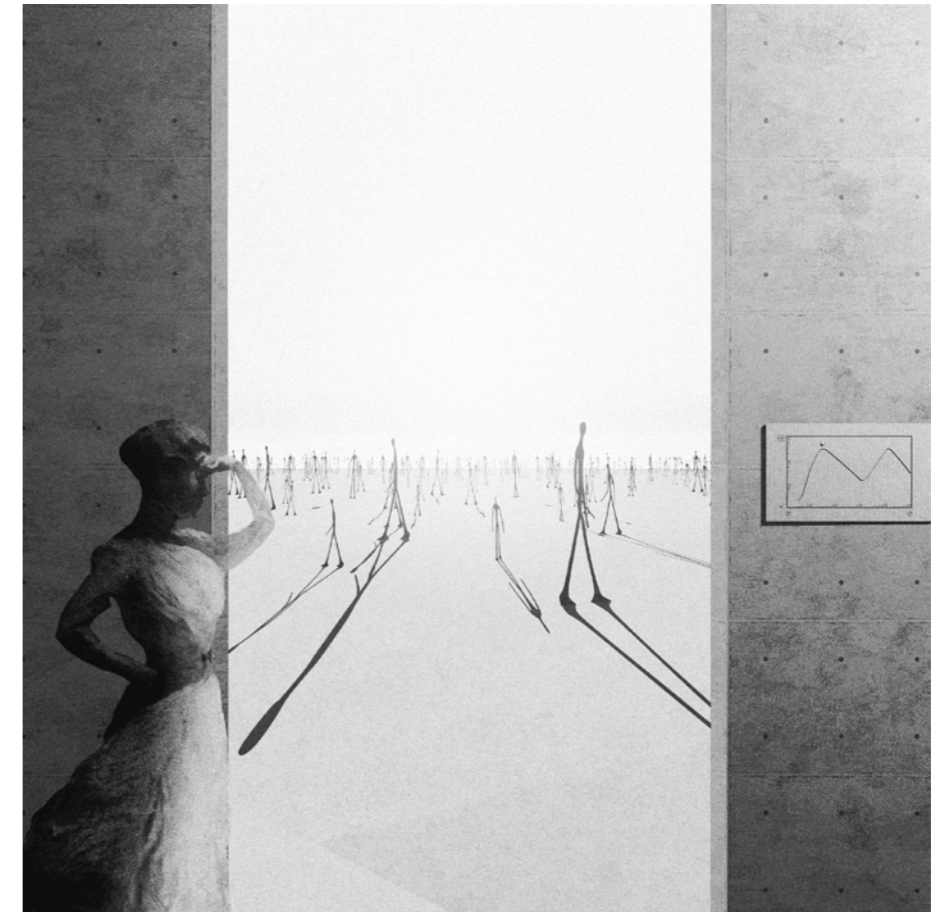

fig 3. flash 1



fig 4. flash 2



fig 5. saviour or reckoning?

fig 6. superimposed on Nevada Test Site



Memories of the Future

Social shelter for the immigrants of the past and future
 InDeSem | Competition | Shortlisted top 5 | 2019

For InDeSem we designed a pavillion at the tip of the kop van zuid in Rotterdam, right next to Hotel New York and the port authority. This part of Rotterdam has a rich multicultural history as the place where people would get onto ships to emigrate to the New World (america) or get off of ships to immigrate to europe. While the history of the port is aimed towards the west, it's future is aimed at the east. Currently 9/10 of the worlds biggest harbors are in Asia, Rotterdam being number 6 and the only western harbor on the list. All of the people from all these different cultures need a space to remind them of home, to remenisce on the past and look towards the future.

We feel that mankinds sense of home doen't come from the shape or material of the house, or the colors of the walls, but rather from nature. When you see and smell the plants that are native to yourpast you get a feeling of nostalgia and you feel like you are at home for a minute. We created a floating platform that is anchored to it's location by the plants and trees that grow from below the ground. There exists a triangular passageway that runs exactly from the east to the west to remind us of the history and future of the harbor. The floor is made of wood that is reclaimed from old ships to give new purpose to the material. Lastly the walls are made translucent to incite a sense of wonder that is part of the identity of the harbor city.

1 week collaboration with: Laudza Az Zahra and Tillman Pospischil

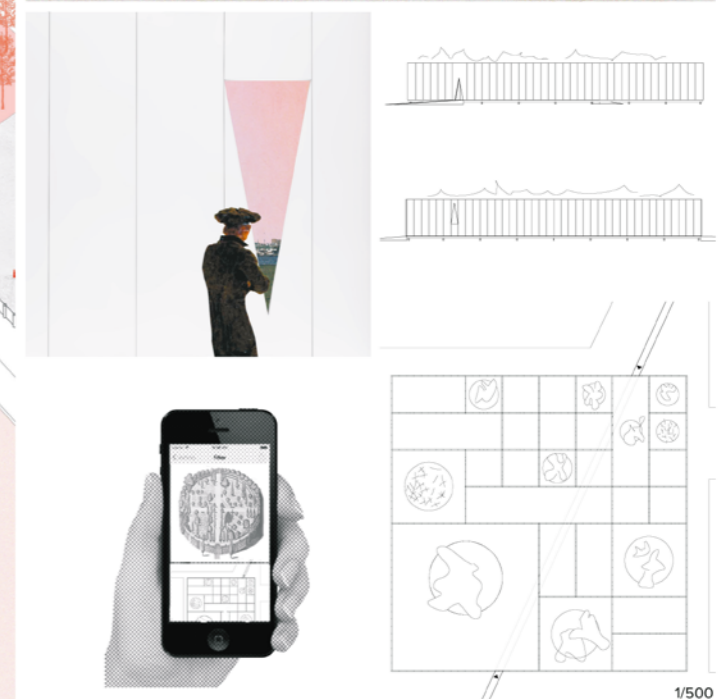
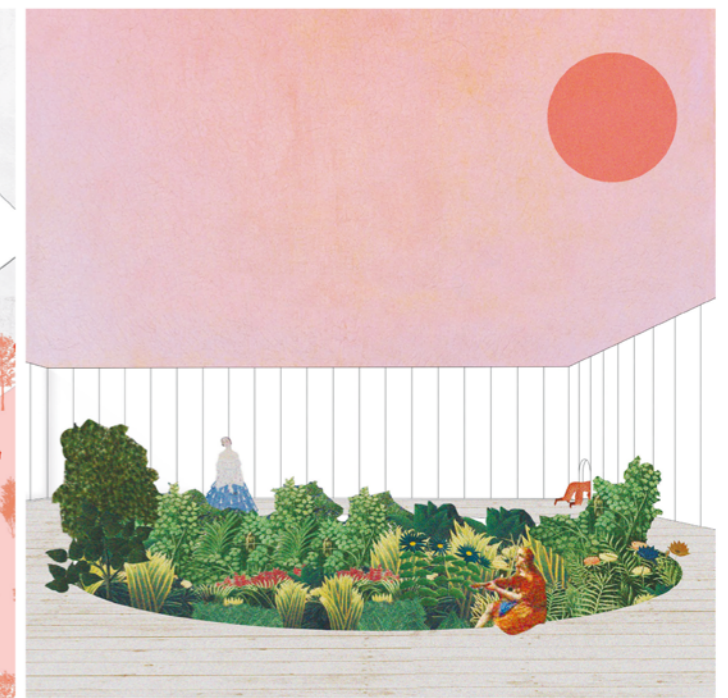
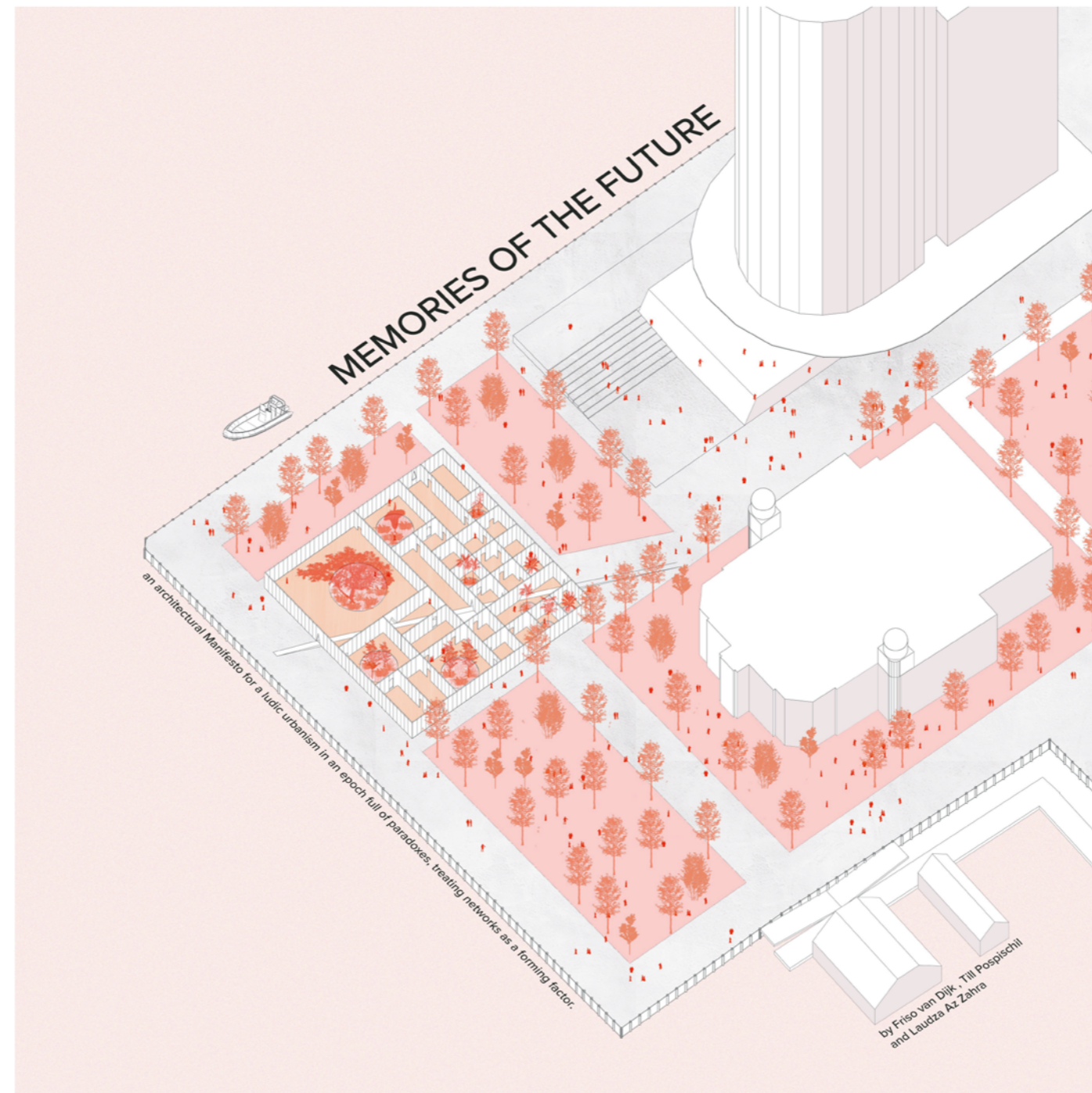

fig 1. presentation board



fig 2, 3, 4 and 5. physical model (built in a single day)



By repuzzling **history** we rediscover the local architecture and we chart a new course for the **public space** and reimagine history in a more obvious way to give physical and cultural **shelter** to the user.

By designing for the **local needs** we aim to create an architecture that evokes the paradoxical **global nature** of the location and incites the **curiosity** that characterizes Rotterdam and will allow us to breach our echo chamber.

By using the failed post world war grid as a **framework** wherein we can play with the paradoxes of the planning process having to deal with the **past, present and future**, we aim for a more playful approach to urbanism which leaves space for **wonders and experiences**.

We feel like temporal paradox of this location is an **opportunity** rather than a threat, architecture has the opportunity to draw from the past and influence the future. By designing with the new **digital tools** we as architects are able to **solve problems** we couldn't solve and weren't aware of before.

We believe architecture is evolving to a point where social networks drive us to **design for other architects**, to chase the beautiful and **superficial image**, rather than solving society's problems. Being aware of the use of contemporary visualisation tools like hyperactive collages and exuberant axonometric drawings we aim to point toward this fact that it is acceptable to use these types of communicating tools but not **mandatory**.

fig 6. daily manifesto, every passing day the previous days' manifesto fades away more.



Photography



Lost in Mars | Awarded "Official Selection" at URBAN Photo Awards | Featured in Exhibition at Trieste Airport for Trieste Photo Days



The Crown of Industry | Featured in online Exhibition at Matca Gallery, Hanoi



Archipelago

Living and playing islands in the harbour of Rotterdam
TU Delft | Academic | 2021

Interactive Architecture studio during the first year of the Master of Science at TU Delft. The point of the course was to design architecture that has its own personality and engages with the participant in a deeper way than simply reactionary. In doing so the studio focusses on highly technical concepts and systems that are enmeshed with concepts for Artificial Intelligence.

Archipelago is a project initially based on the River Maas in Rotterdam but could be spread to any location where water exists. It is an island-looking form that gives people an opportunity to interact with the water, but also with the building itself in a new way. Through the implementation of AI, this piece of architecture gained its own personality which depends on its mood, environmental circumstances, and visitors which it is interacting with.

The building consists of two parts, the brain, which processes all information and turns it into movement patterns and the body, which translates rotational movement downstairs into vertical movement on the top surface. A set of electromotors in the brain turn rods, that connect to pulleys in the body which pull and release cables that are attached to the surface above the water. The whole machine is effectively a balloon full of water that moves water around within itself to reposition the top surface in relation to the river.

[Click here to go to my website for the animations / videos of the script.](#)

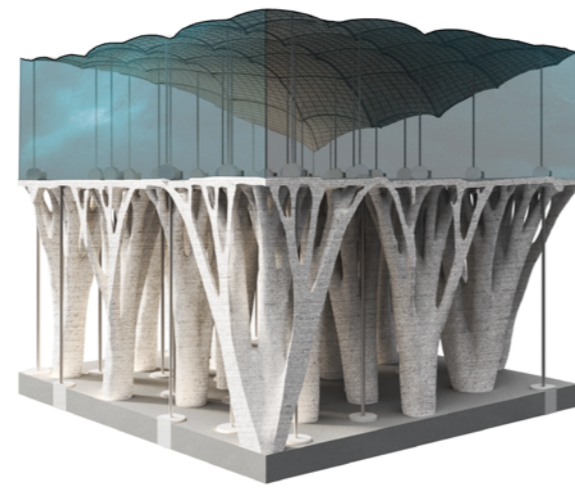

fig 1. higher resolution optimized structure, also shows the rope pattern underneath the top surface

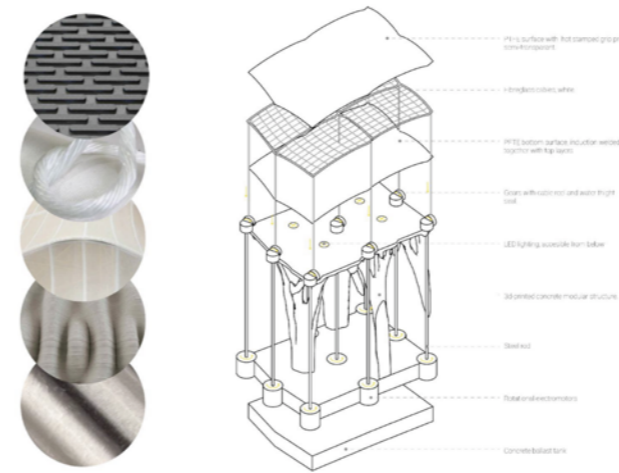

fig 2. structure of the top membrane, machine function fragment

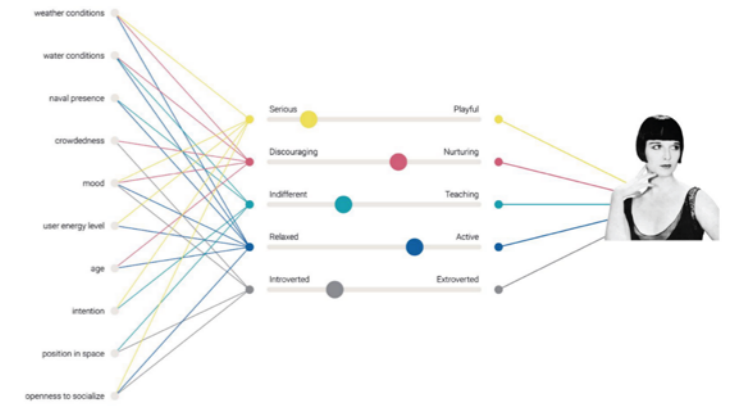

fig 3. sensor input to building personality



fig 4. exterior render



fig 6. section

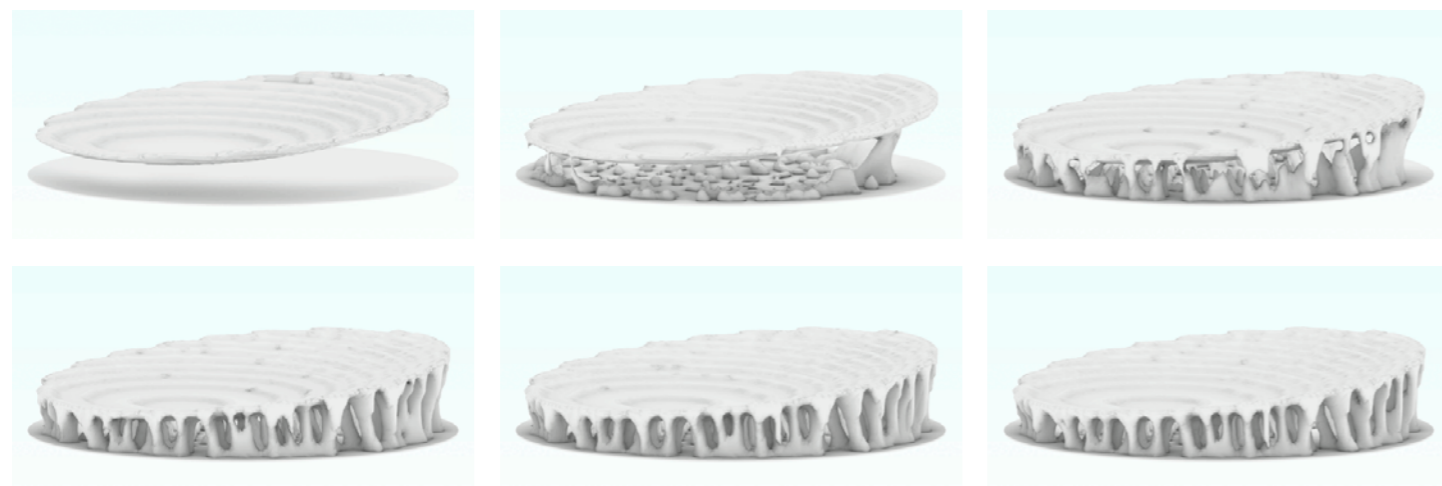

fig 5. low resolution replication of the optimization used for the structure



fig 7. interior render

Archipelago

The Enclave

Reclaiming Commercial Space for Art
TU Delft | Academic | Building Engineering Science | 2020

Sloterdijk is currently a very corporate and frankly dead place. In order to slowly build towards a livable residential zone a lot has to change over time. To start this process the project tasked us with renovating the former Tax office into a residential building. Due to the spirit of the place and the current conditions not being right for residential use this building creates an opportunity for a project that calls to action, rather than just exists.

Artists have been leaving Amsterdam for over 20 years, the prices are too high and there are too few studio spaces available. They have been priced out of all the spaces they occupy by the relentless march of the real estate developers. They do not have a place within a system where buildings are seen more as vehicles for financial speculation than a requirement for life. They are a group that does not require a location to be neutered of all personality before they move in.

The project, then, became a sort of protest against this real estate mentality. Approaching the point where the Return on Investment is nearing its absolute minimum. Where the old Tax office is turned into a handfull of artist studios and a museum below.

In the end this is a technical project that according to the syllabus was not supposed to revolve around the conceptual. But rather a more detail oriented approach. In an effort to create the 'ideal' studio a special facade element was designed that interlocks and is fully dismountable to create a more circular system. Behind the boxes is a second facade which exists for two reasons. It creates a heat chimney, which creates ventilation and it can be switched between translucent and transparent, which means the artist can always create the ideal diffuse 'North' light, regardless of the orientation of their studio.

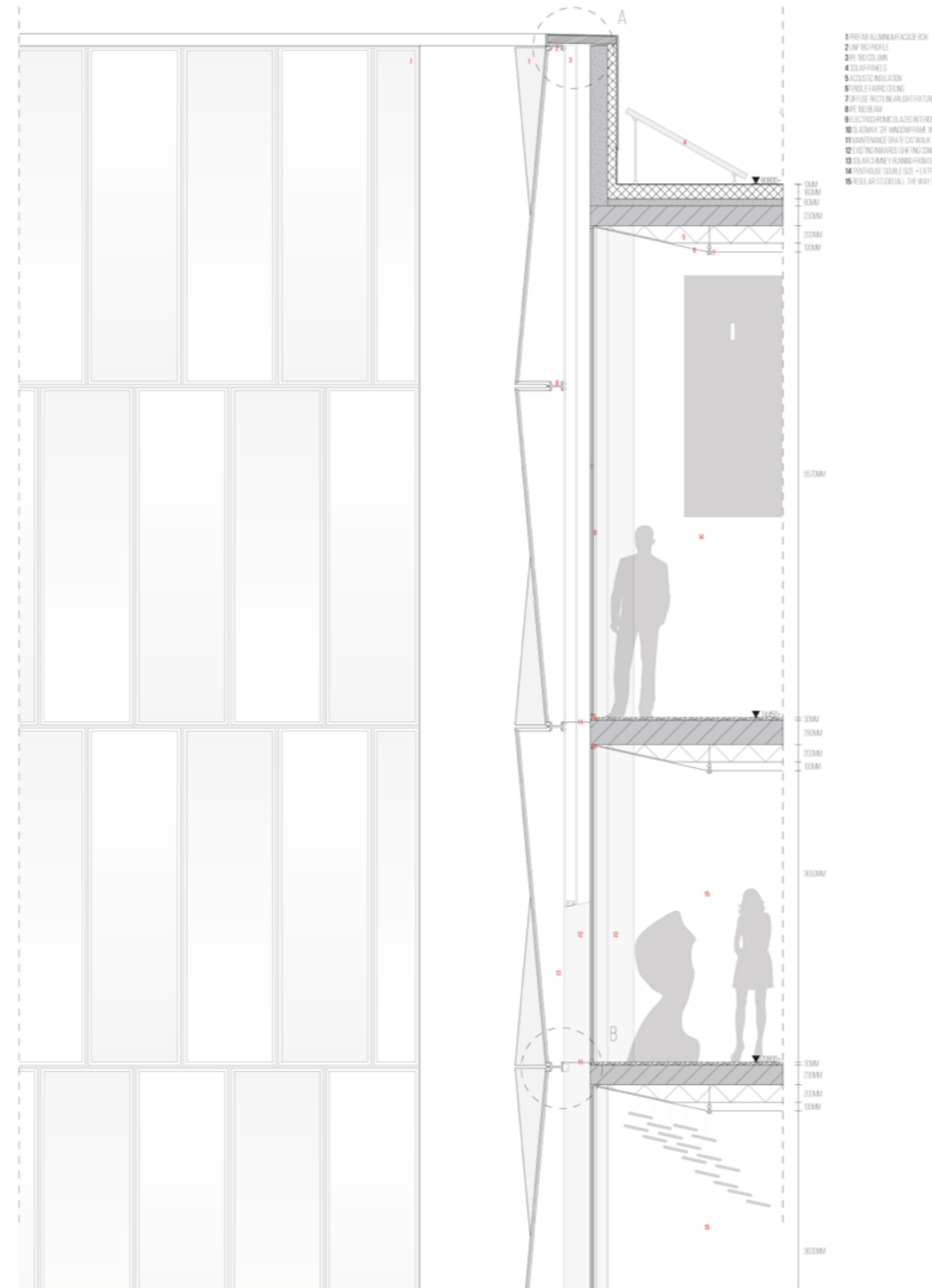

fig 2. 1:20 elevation, 1:20 section

SECTION AA 120

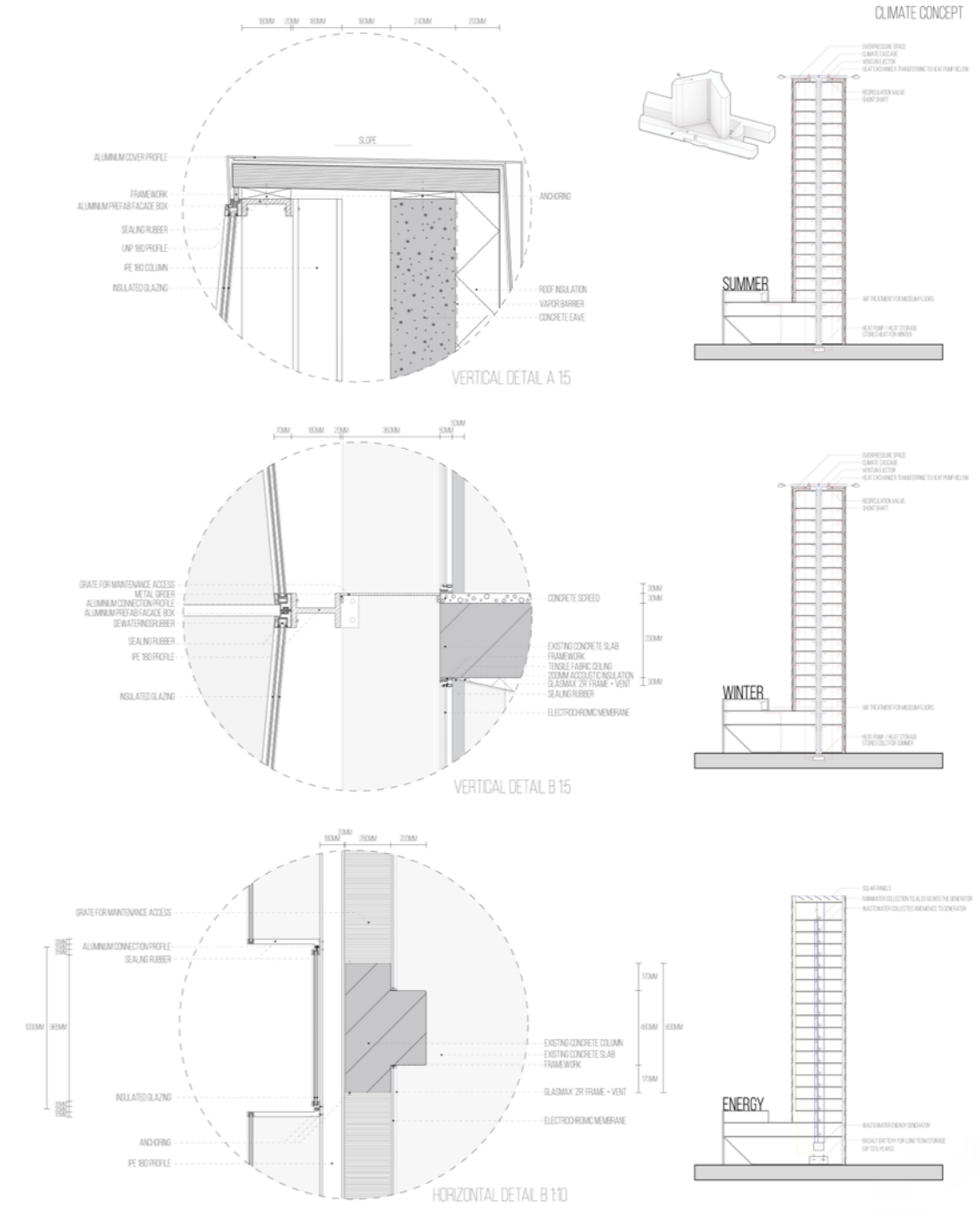

fig 4. 1:5 details, climate concepts



fig 1. facade impression, rendered, sky reflection



fig 3. 3D facade connection detail



fig 5, 6. interior render (transparent), interior render (opaque)



The Enclave

A Moment Captured

Reimagining data as a tool for reliving precious memories
InDeSem | 24hr Competition | 2021 | Honourable mention "Most Beautiful Nightmare"

fig 1. presentation board



A MOMENT CAPTURED

INDESEM.21 GR 3A // Julia Ravensbergen // Friso van Dijk // Jules Bresson // Oviya Elango

Data consists of 1s and 0s, cold binary code, detached from that which makes us human. Yet these numbers can be turned into pixels, which in turn create images, which can trigger memories. You are moving down a binary road and meet a building, 1 goes in, 0 moves on. To go in you initiate a handshake with the building, its door opens. Inside is a holographic 3D representation of one of your most intimate memories. A moment captured, by those you know were present, but also by the ever watching sensorscape of the world. All these angles and media combined create a memory with more details than you notice in the moment. You walk around through the memory, inspecting it from all perspectives. You notice the way a loved one squeezes in a hug or the expression on a parent's face as they watch you leave. Now it is time to leave, to let go and to return, to the binary road.

Binary road

Initiate interaction

Relive moment

Binary road

A Moment Captured

David after Goliath

Rendering a simulation of Cloth, Liquids and Particles.
TU Delft - Beyond3D | Academic | 2021

After the earth has turned to desert David returns to the massive corporate cathedral. Just as the air, what once was his has turned to dust, he finds his statue has crumbled. He touches a physical reminder of the ruin his own greed brought upon the world.

A render and set of studies made for the short elective Beyond 3D. The point of the course was mostly to learn how to model and render cinematic scenes in Autodesk Maya. With a heavy focus on learning how to simulate cloth physics, liquid physics and particle physics. To that end I decided I was interested in creating a scene inspired by Olafur Eliasson's 'The Weather Project' and Blade Runner 2049. In both there is a heavy emphasis on the monochromatic aspects and dusty / diffuse particle rich air. Which seemed like an interesting challenge.

Modelling the person and simulating how cloth falls around them ended up being one of the most complex aspects of the project even though they only take up a tiny amount of the final image. The entire scene is quite simulation heavy as that was most interesting to me. Mainly the oily / sludgy liquid in the basin and the interaction between dust in the air and diffusion of the sun ended up becoming quite complex. On my website ([click here](#)) there are some studies and images related to the process of making this single image and its simulated parts.

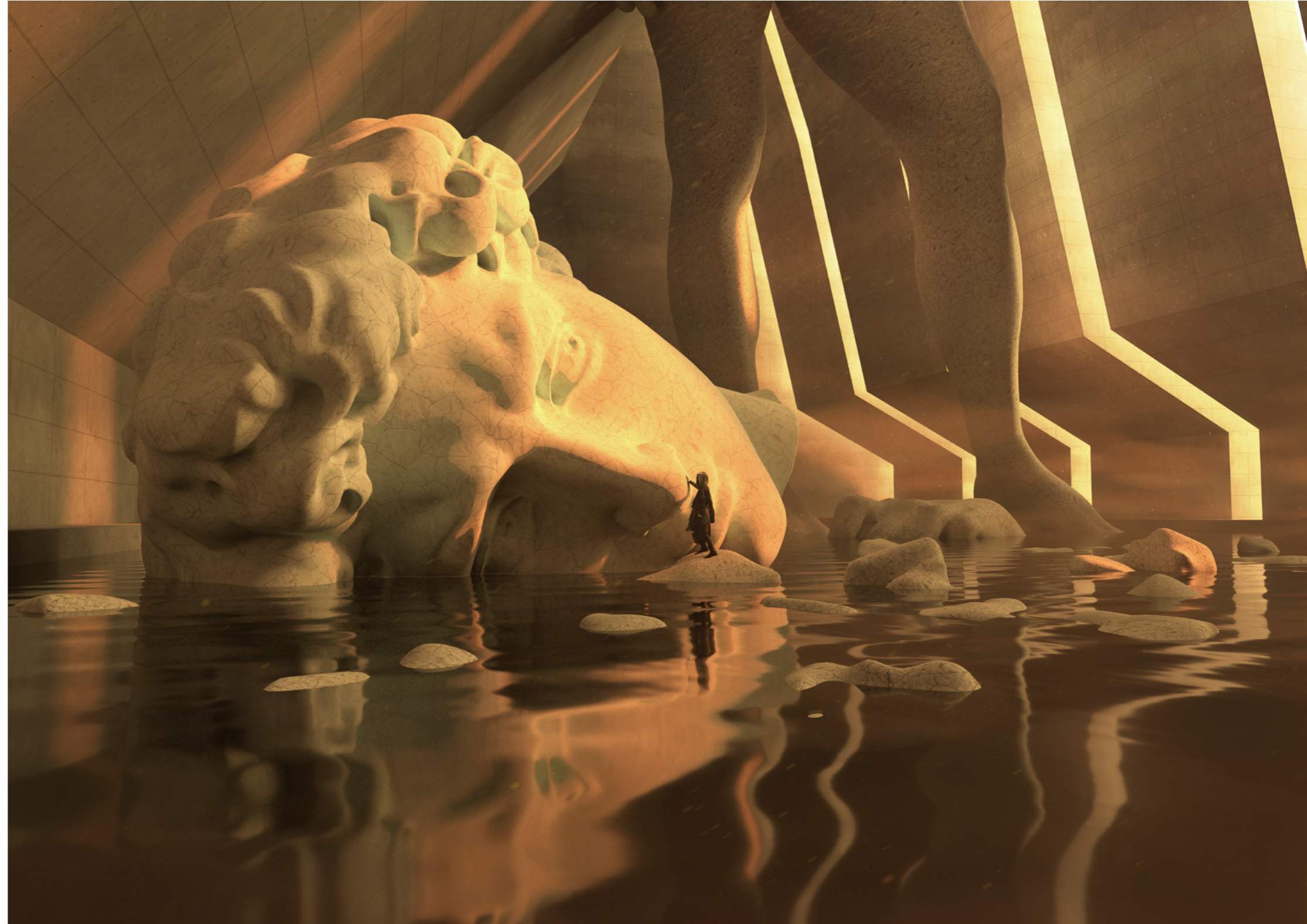



Thank you

Friso van Dijk
+316 39 121 619
friso@frisovdijk.com